

# *GSE Model 250*

Digital Indicator



Technical Reference Manual  
Version 1.1







# Table of Contents

<b>1.</b>	<b>INTRODUCTION</b> .....	<b>3</b>
1.1.	Overview .....	3
1.2.	Approvals (for trade versions only).....	3
1.3.	The Manuals Set .....	3
1.4.	Document Conventions .....	4
<b>2.</b>	<b>SPECIFICATIONS</b> .....	<b>5</b>
<b>3.</b>	<b>INSTALLATION</b> .....	<b>6</b>
3.1.	Introduction .....	6
3.2.	General Warnings .....	6
3.3.	Electrical Safety .....	6
3.4.	Cleaning .....	6
3.5.	Panel Mount Template .....	6
3.6.	Cable Connections .....	6
3.7.	DC Power (DC PWR + , DC PWR –) .....	7
3.8.	Load Cell Connection .....	7
3.8.1.	Load Cell Signals and Scale Build .....	7
3.8.2.	4-Wire Connection .....	7
3.8.3.	6-Wire Connection .....	8
3.9.	Auxiliary Connections .....	8
3.9.1.	RS-232 Serial .....	8
3.9.2.	Remote Input .....	9
3.9.3.	Outputs .....	10
3.10.	GSE-LINK (Optional).....	10
3.11.	Connecting Shields .....	11
3.11.1.	Cable Shield Connection and Earthing .....	11
3.12.	Regulatory Sealing Requirements .....	11
<b>4.</b>	<b>DATA ENTRY</b> .....	<b>12</b>
4.1.	Editing Annunciators .....	12
4.2.	Numeric Entry .....	12
4.3.	Selections and Options .....	12
<b>5.</b>	<b>BASIC OPERATION</b> .....	<b>14</b>
5.1.	Display and Controls .....	14
5.1.1.	Front Panel: Visual Display .....	14
5.2.	Operation Keys .....	15
5.2.1.	Primary Function .....	15
5.2.2.	Editing Function .....	15
5.3.	Stability Considerations .....	15
5.4.	POWER Key .....	15
5.4.1.	Automatic Operation .....	15
5.5.	ZERO Key .....	15
5.6.	TARE Key .....	16
5.7.	GROSS/NET Key .....	16
5.7.1.	GSE-LINK Activation .....	16
5.8.	PRINT Key .....	16
5.9.	FUNCTION Key .....	16
<b>6.</b>	<b>CONFIGURATION ISSUES</b> .....	<b>17</b>
6.1.	General Setup Information .....	17
6.2.	Basic Weighing Terminology .....	17
6.3.	Filtering Techniques .....	18
6.4.	Industrial vs OIML and NTEP Modes .....	18
6.5.	Calibration Counter .....	18
6.6.	Passwords.....	19
6.6.1.	Full Setup Password .....	19
6.6.2.	Safe Setup Password .....	19
6.6.3.	Setup Lock-Out .....	19
<b>7.</b>	<b>SETUP</b> .....	<b>20</b>
7.1.	Accessing Setup .....	20
7.1.1.	Setup Display Prompts .....	20

7.2.	Exiting Full or Safe Setup.....	20
7.3.	Groups and Items.....	21
7.3.1.	GRP (Group).....	21
7.3.2.	ITM (Item).....	21
7.4.	Setup Menus.....	21
7.4.1.	BUILD (Scale Build).....	21
7.4.2.	OPTION (Scale Options).....	22
7.4.3.	CAL (Scale Calibration).....	23
7.4.4.	SPEC (Special Settings Menu).....	23
7.4.5.	SERIAL (Serial Communications Options).....	25
7.4.6.	SET.PTS (Setpoint Settings).....	25
7.4.7.	CLOCK (Clock Settings).....	26
7.4.8.	TEST (Special Test Functions).....	26
7.4.9.	FACTRY (Factory Adjustment Menu).....	27
7.4.10.	– End – (Leaving Setup).....	27
<b>8.</b>	<b>CALIBRATION.....</b>	<b>28</b>
8.1.	Performing a Digital Calibration with Test Weights.....	28
8.1.1.	ZERO (Zero Calibration Routine).....	29
8.1.2.	SPAN (Span Calibration Routine).....	29
8.2.	Performing a Calibration with Direct mV/V Entry.....	29
8.2.1.	DIR.ZER (Direct Zero Calibration Entry).....	29
8.2.2.	DIR.SPN (Direct Span Calibration Entry).....	29
8.3.	Using Linearization.....	29
8.3.1.	ED.LIN (Edit Linearization Points).....	30
8.3.2.	CLR.LIN (Clear linearization).....	30
<b>9.</b>	<b>SERIAL OUTPUTS.....</b>	<b>31</b>
9.1.	Automatic Weight Output.....	31
9.2.	Master Serial Output.....	32
<b>10.</b>	<b>SETPOINTS.....</b>	<b>33</b>
10.1.	Setpoint Connection.....	33
10.2.	Setpoint Operation.....	33
<b>11.</b>	<b>SPECIAL FUNCTIONS.....</b>	<b>34</b>
11.1.	Introduction.....	34
11.2.	Key Functions.....	34
11.2.1.	NONE.....	34
11.2.2.	TEST.....	34
11.2.3.	COUNT.....	34
11.2.4.	UNITS.....	34
11.2.5.	HOLD and PEAK HOLD.....	34
11.2.6.	LIVE.WT.....	35
11.2.7.	SHOW.T.....	35
<b>12.</b>	<b>APPENDIX.....</b>	<b>36</b>
12.1.	Dimensions.....	36
12.2.	Sealing Details.....	37
12.3.	Setup Menu Quick Reference.....	38
12.4.	Error Messages.....	39
12.4.1.	Weighing Errors.....	39
12.4.2.	Setup and Calibration Errors.....	39
12.5.	Diagnostic Errors.....	40
12.6.	Glossary Terms.....	40
12.7.	List of Figures.....	41
12.8.	List of Tables.....	41
<b>13.</b>	<b>INDEX.....</b>	<b>42</b>

# 1. Introduction

This instrument is a precision digital indicator using the latest Sigma-Delta A/D technology to ensure fast and accurate weight readings.

The setup and calibration of the instrument are digital, with a non-volatile security store for all setup parameters.

The instrument may be operated from either 4 AA batteries or a DC power source from 12V to 24V. There is a soft power on/off function that retains memory of its state. Once an instrument is turned on it will automatically start up again if the external power is interrupted.

The instrument is fitted with GSE-LINK communications as standard. This allows a temporary isolated communications link to be established with a PC and enables software upgrades and the use of computerized setup and calibration via the Viewer software. Refer to GSE-LINK (Optional) page 10 for more information.



*Figure 1: Weight Indicator*

## 1.1. Overview

This instrument provides the **ZERO** and **TARE** functionality as well as providing more setup options (e.g. serial and setpoints) and printing functionality.

It also supports special functions (e.g. peak-hold, live weight (livestock) averaging, counting, etc.), via the user definable <FUNCTION> key. It is equipped with an NVRAM store to ensure day-to-day operating settings (e.g. **ZERO**, **TARE**, **CLOCK**, etc.), are retained when power is removed.

This instrument has two isolated transistor outputs with status display on the front panel as well as the RS-232 communications port that can be used for printer driving or connection to a remote display or PC. There is a built-in clock for date-stamping printed outputs.

## 1.2. Approvals (for trade versions only)

- NSC approval (4000 divisions at 0.8 $\mu$ V/division).
- NMI approval (4000 divisions at 0.8 $\mu$ V/division).
- C-tick approved and CE approved.

## 1.3. The Manuals Set

This manual is part of a set of manuals covering the setup and operation of the instrument. The set includes the following:

- **Technical Reference Manual** - Contains detailed information on calibration and setup. This manual is intended for use by Scale Technicians who are installing the instrument.
- **Operator Manual** - Aimed at the operation of the instrument, and covers the day-to-day operation of the instrument.
- **Quick Start Manual** - Intended for Scale Technicians who are familiar with the instrument and simply need a quick reference to menu options and connection diagrams, etc.
- **Communications Manual** - Contains details on the extended networking capabilities (communications protocol).

## 1.4. Document Conventions

The following document conventions (typographical) are used throughout this Reference Manual.

<b>Bold Text</b>	Bold text denotes words and phrases to note.
<b>&lt;Key&gt;</b>	<b>&lt;Key&gt;</b> denotes a Keypad key. <b>Note:</b> In the Specifications section the < symbol means <b>less than</b> and the > symbol means <b>greater than</b> .
^	This symbol denotes one space (used in Automatic Weight Output page 31)
⊗	Items marked with ⊗ indicate that the setting is available only in Full Setup and is trade critical. When trade critical settings are changed the calibration counter will be incremented.



## 2. Specifications

Performance		
Resolution	Up to 30,000 divisions, minimum of 0.25 $\mu$ V/division, 20 updates/second (Trade 4000 divisions at 0.8 $\mu$ V/division)	
Zero Cancellation	$\pm$ 2.0mV/V	
Span Adjustment	0.1mV/V to 3.0mV/V full scale	
Stability/Drift	Zero: < 0.1 $\mu$ V/ $^{\circ}$ C (+ 8ppm of deadload max) Span < 8 ppm/ $^{\circ}$ C, Linearity < 20ppm, Noise < 0.2 $\mu$ Vp-p	
Excitation	5 volts for up to 4 x 350 or 8 x 700 ohm load cells (4-wire or 6-wire plus shield) Maximum total load cell resistance: 1,000 ohms	
A/D Type	24bit Sigma Delta with 8,388,608 internal counts	
A/D Conversion Rate	20Hz with FIR filtering > 80dB	
Operating Environment	Temperature: 14 to 122 $^{\circ}$ F ambient Humidity: <90% non-condensing Storage: -4 to 122 $^{\circ}$ F ambient IP55 when panel mounted	
Case Materials	ABS, Silicon Rubber, Nylon, Acrylic (no halogen used)	
Packing Weights	Basic Indicator: 0.75lb	
Digital		
Display	LED Backlit LCD with six 0.8" high digits with units and annunciators	
Setup and Calibration	Full digital with visual prompting in plain messages	
Digital Filter	Sliding window average from 0.1 to 4.0 seconds	
Zero Range	Adjustable from $\pm$ 2% to $\pm$ 20% of full capacity	
Power Input		
Standard Power Input	12 to 24VDC (2.5 VA max) - ON/OFF key with memory feature	
Variants	AC	Wall Transformer: 110/240VAC 50/60Hz in 12VDC 0.5A out
	Battery	4 x AA batteries (Alkaline or rechargeable NiMH, NiCad, etc.)
Features		
GSE-LINK Data Coupling	Infra-red Connector for optional GSE-LINK PC cable (to RS-232 PC port)	
Correction	Five point linearity correction	
Outputs	RS-232 automatic transmit, network or printer outputs. Transmission rate: 2400, 4800 or 9600 baud	
Assignable Function Key	Unit switching, counting, manual hold, peak hold, live weight and totalizing	
Drive Outputs	2 isolated transistor drive outputs (300mA total at 50VDC)	
Battery Backed Time/Date Clock	Battery life 10 years minimum	

## 3. Installation

### 3.1. Introduction

The following steps are required to set up the indicator.

- Inspect indicator to ensure good condition.
- Use connection diagrams to wire up load cell, power and auxiliary cables as required.
- Use the drill hole template provided for hole locations.
- Connect Power to indicator and press <POWER> key to turn the instrument On.
- Refer to the Setup section page 20 for information on configuring and calibrating the instrument.
- To turn instrument Off press and hold <POWER> key for three seconds (until display blanks).

### 3.2. General Warnings

- Indicator not to be subject to shock, excessive vibration or extremes of temperature (before or after installation).
- Inputs are protected against electrical interference, but excessive levels of electro-magnetic radiation and RFI may affect the accuracy and stability.
- The instrument should be installed away from any sources of excessive electrical noise.
- The load cell cable is particularly sensitive to electrical noise and should be located well away from any power or switching circuits.
- For full EMC or for RFI immunity, termination of cable shields and correct earthing of the instrument is essential.
- Indicator and load cell cable are sensitive to excessive electrical noise. Install well away from any power or switching circuits.

### 3.3. Electrical Safety

- For your protection all electrical hardware must be rated for environmental conditions of use.
- Pluggable equipment must be installed near an easily accessible power socket outlet.
- To avoid the possibility of electric shock or damage to the instrument, always switch off or isolate the instrument from the power supply before maintenance is carried out.

### 3.4. Cleaning

- To maintain the instrument, never use harsh abrasive cleaners or solvents. Wipe the instrument with a soft cloth **slightly** dampened with warm soapy water.

### 3.5. Panel Mount Template

Use the panel mount template for drill hole locations. The template indicates positions for the two 4mm mounting screws through the panel. Also displayed on the template is the position of the rectangular hole that should be cut to allow for the connection of cables. The drilling template supplied with the indicator allows for front or rear machining of the panel.

### 3.6. Cable Connections

All cable connections are made to the rear of the instrument using screwless terminals. Wires must be stripped of insulation by at least 10mm. To install, depress the orange lever beside the terminal required and push wire into the hole. Release the lever and pull gently on the wire to ensure it is securely trapped in the terminal. It is not necessary to tin the ends of the wire with solder or to add crimp ferrules to the wires, however, these techniques are also compatible with the terminals and may ultimately make for a neater job.

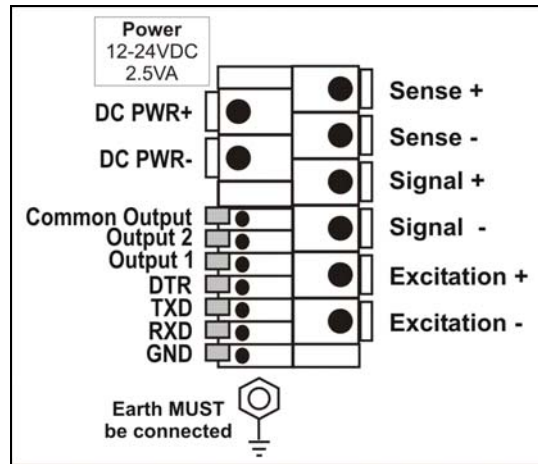

Figure 2: Cable Connections

### 3.7. DC Power (DC PWR + , DC PWR –)

The DC supply need not be regulated, provided that it is free of excessive electrical noise and sudden transients. The instrument can be operated from a high quality AC wall transformer as long as there is sufficient capacity to drive both it and the load cells.

### 3.8. Load Cell Connection

#### 3.8.1. Load Cell Signals and Scale Build

Very low output scale bases may be used but may induce some instability in the weight readings when used with higher resolutions. Generally speaking, the higher the output, or the lower the number of divisions, the greater the display stability and accuracy.

The instrument can display the milliVolt-per-Volt reading that can be used to check scale base signal output levels. For more information, refer to SCALE (Scale Base Test Display) page 26.

The instrument may be connected for either 4-wire or 6-wire operation. To correspond with the actual cabling installation the instrument must be configured in setup to the correct setting. For more information, refer to CABLE (4-Wire or 6-Wire) ⊗ page 22.

#### 3.8.2. 4-Wire Connection

The minimum connectivity requirements are the connection of four wires (i.e. Excitation + and – along with Signal + and –). Internally the instrument has a precision analog switch that can be used to connect the Sense + and – lines directly to the Excitation + and – lines.

Any addition to the load cell manufacturer's cable length using 4-wire connection, is only recommended for short cable runs. Where long additions to cable lengths are needed, a 6-wire extension is required.

The BUILD:CABLE option must be set to 4 to allow for 4-wire connection. Refer to CABLE (4-Wire or 6-Wire) ⊗ page 22.

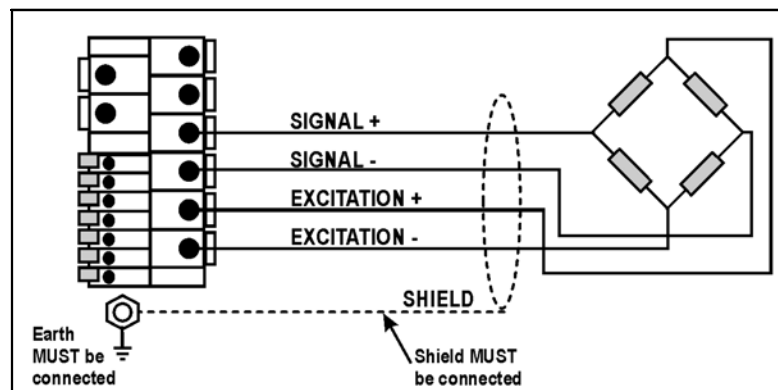
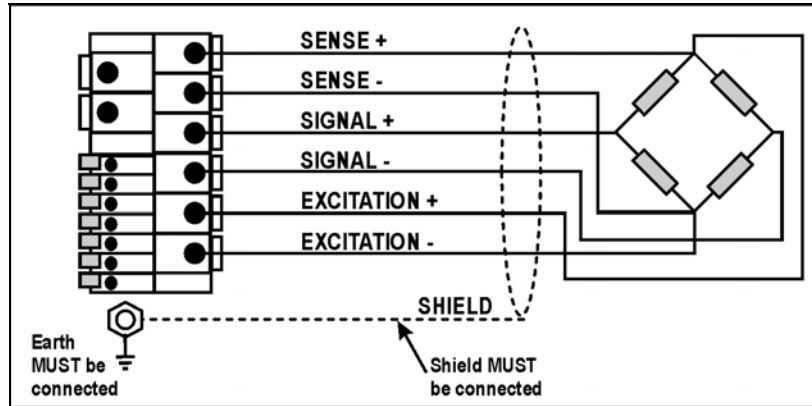

**Figure 3: 4-Wire Connections**

### 3.8.3. 6-Wire Connection

The excitation and signal lines are connected the same as for a 4-wire installation. The extra two wires (Sense + and -) should be connected to the Excitation + and - lines as close as possible to the load cell itself. Typically these connections are made in a load cell termination box.

The BUILD:CABLE option must be set to 6 (the default) to allow for 6-wire connection. Refer to CABLE (4-Wire or 6-Wire) ☉ page 22.



**Figure 4: 6-Wire Connections**

## 3.9. Auxiliary Connections

This section provides diagrams to illustrate the terminal connections.

### 3.9.1. RS-232 Serial

- Direct Personal Computer Link (RXD, TXD, GND)

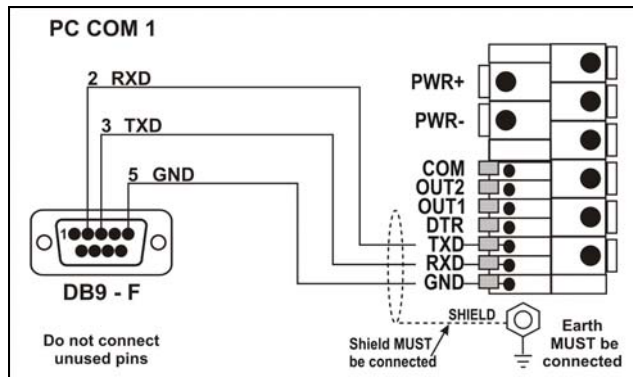

**Figure 5: RS-232 - Instrument to PC using COM Port (DB9)**

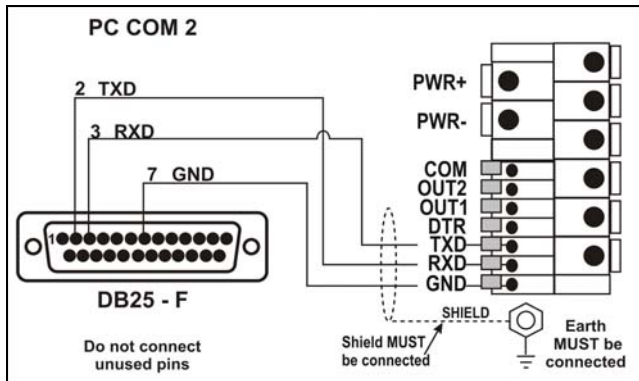

Figure 6: RS-232 – Instrument to PC using COM Port (DB25)

- Printer Connections (RXD/TXD, GND and DTR)

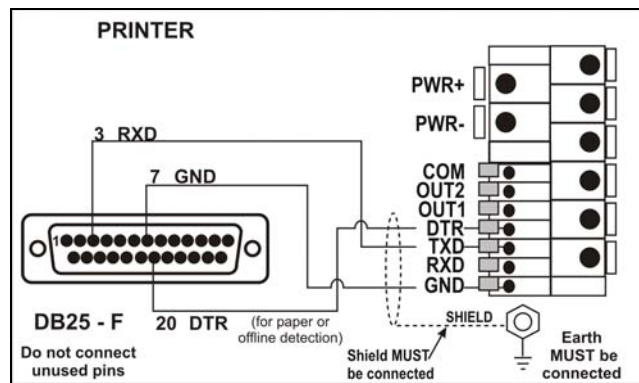

Figure 7: RS-232 – Instrument to Printer (DB25)

- Remote Display (TXD, GND)

The remote display documentation should be referred to for connection details. Connect TXD to RXD and GND to GND on the remote display.

### 3.9.2. Remote Input

The indicator requires a voltage free contact between TXD and RXD to enable the remote input (ie. SPEC:REM.FN). **Note:** The remote input will not function when in setup or when using the opto-LINK.

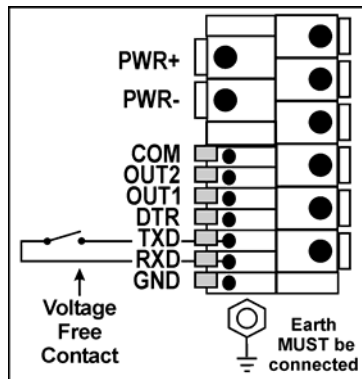

Figure 8: Remote Input

**WARNING**

The remote input is a voltage free contact (eg. button, mechanical relay). Connection of any active circuitry may damage the instrument.

### 3.9.3. Outputs

The output drivers for the instrument are isolated open emitter transistor drives that are capable of driving up to a total of 300mA. This configuration allows for the direct connection of the instrument outputs to most PLC types.

The voltage applied to the COM terminal appears on the output lines (i.e. OUT1 and OUT2) when the outputs are active (e.g. to connect to a PLC connect +24V to the common terminal). The outputs can then be connected directly to PLC inputs so when activated the PLC will see the 22V signal (approx. - the exact switch loss will depend on loading of the output).

To drive external loads (e.g. relays), connect the relay coil positive supply to the output common and the output line directly to one side of the relay coil. Connect the other end of the relay coil to the negative supply. It is recommended that fly-back diodes or transient suppressors be fitted across relay coils to limit switching noise.

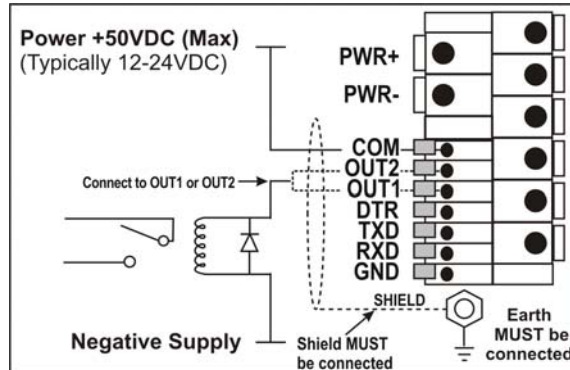

**Figure 9: Instrument Outputs to Drive Relay**

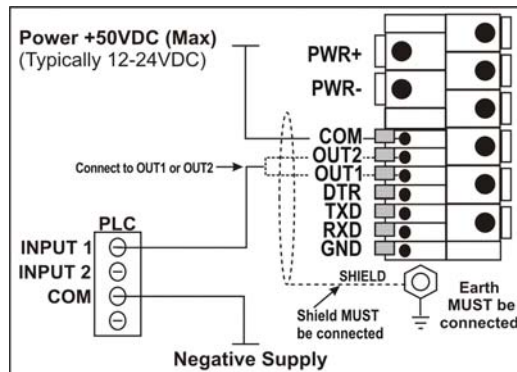

**Figure 10: Instrument Outputs to Drive PLC**

### 3.10. GSE-LINK (Optional)

A temporary infrared communications link can be established between the instrument and a PC using an optional GSE-LINK cable. The optional GSE-LINK cable can be used to transfer setup and calibration information from a PC (e.g. to be stored for later use and/or transferred to other instruments). It can also be used to download software upgrades to the instrument from a PC.

The PC end of the GSE-LINK cable is a standard female DB9 connector. The instrument end of the cable consists of an infrared transceiver, which attaches to the left side of the instrument display. To facilitate a quick and simple connection, the infrared transceiver is secured in place by a permanent magnet located within the head of the GSE-LINK.

Refer to GSE-LINK Activation page 16 for more information.

**WARNING**  
The GSE-LINK head contains a strong magnet and care should be taken with it's proximity to electronic media (e.g. credit cards, floppy disks, etc.) and/or other electronic instrumentation.

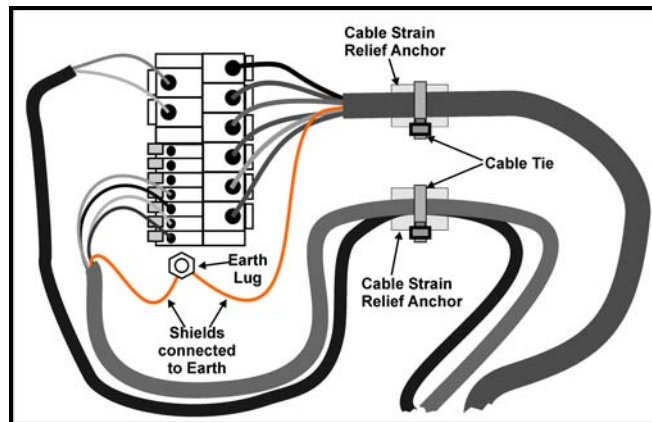

**Figure 11: GSE-LINK Attachment**

### 3.11. Connecting Shields

To obtain full EMC or for RFI immunity, cable shields MUST be connected to the earth lug on the rear of the instrument.

Figure 12 illustrates an example of possible connections. Also shown are the connecting cables restrained using cable ties fastened around the cable strain relief anchors.



**Figure 12: Cable Shield Connection**

#### 3.11.1. Cable Shield Connection and Earthing

- Care should be taken when connecting shields to maximize EMC or RFI immunity and minimize earth loops and cross-talk (interference) between instruments.
- For full EMC or for RFI immunity, termination of the cable shields at the earth lug is very important. The earth lug of the instrument must be separately connected to ground potential via a reliable link.
- The instrument should only be connected to earth via a single reliable link to avoid earth loops.
- Where each instrument is separately earthed, interconnecting cable shields should be connected at one end only.
- **Caution:** Some load cells connect the cable shield directly to the load cell (and therefore the scale base). Connection of the load cell cable shield in this situation may be site specific.

### 3.12. Regulatory Sealing Requirements

To comply with regulatory sealing requirements for each instrument, (i.e. to ensure instruments are not accidentally or deliberately tampered with), it is important that proper sealing procedures be adhered to. Refer to Sealing page 37 for more information.

## 4. Data Entry

Throughout the setup and normal weighing mode, different data entry methods are used. Each method is described below.

When using the keypad for normal operation, press the key on keypad to initiate the feature.

### 4.1. Editing Annunciators

When in Setup the instrument displays editing annunciators. Figure 13 identifies each of the editing annunciators. When in Setup, press the corresponding keypad key below the annunciator.



**Figure 13: Editing Annunciators**

Annunciator	Key Name	Description
GRP	ZERO	<ul style="list-style-type: none"> <li>Steps through the list of Groups.</li> </ul>
ITM	TARE	<ul style="list-style-type: none"> <li>Steps through the list of Items.</li> <li>Press this key to accept changes and return to the menus.</li> <li>(Also refer to the <b>OK</b> description below.)</li> </ul>
SEL	GROSS/NET	<ul style="list-style-type: none"> <li>Moves the editing cursor in some editing modes.</li> </ul>
EDT	PRINT	<ul style="list-style-type: none"> <li>Steps through the available options when editing a particular item.</li> </ul>
OK	OK (FUNCTION)	<ul style="list-style-type: none"> <li>Press this key to accept changes and return to the menus.</li> <li>(Also refer to the <b>ITM</b> description above.)</li> </ul>

### 4.2. Numeric Entry

A numeric entry box allows the input of a number. When entering a number, the display will show digits with the currently selected digit flashing. The <SEL> key is pressed to select a digit to change. When the digit is selected the <EDT> key is pressed to change the digit from 0 through 9. The left most digit can also be changed to a dash (-) to enter a negative number. The <OK> key is pressed to accept the number that has been entered and return to the menu item.

Upper and lower limits are placed on some entries and an entry outside this range will cause the instrument to display dashes (i.e. - - - - -).

**Example:** When in Setup follow the steps below to set Build, Max Capacity.

- |  |
|--|
| <ul style="list-style-type: none"> <li>Press &lt;GRP&gt; repeatedly to display the <b>BUILD</b> group.</li> </ul>  |
| <ul style="list-style-type: none"> <li>Press &lt;ITM&gt; repeatedly to display the <b>CAP</b> item.</li> </ul>   |
| <ul style="list-style-type: none"> <li>Press &lt;SEL&gt; to select <b>CAP</b> and display the current setting (e.g. 0000.00lb).</li> </ul>   |
| <ul style="list-style-type: none"> <li>The currently chosen digit will be flashing. Press &lt;SEL&gt; to advance to the next digit.</li> </ul>   |
| <ul style="list-style-type: none"> <li>When the digit to edit is flashing, press &lt;EDT&gt; repeatedly to cycle from 0 through 9.</li> </ul>  |
| <ul style="list-style-type: none"> <li>When the new digit to be set is flashing either press &lt;SEL&gt; to move to the next digit to edit and repeat the previous step; or press &lt;OK&gt; or &lt;ITM&gt; to accept all of the displayed digits (including the flashing digit) and re-display the menu item name.</li> </ul> |

### 4.3. Selections and Options

A selection entry requires the choice of a single option from a list. When a Group and Item have been chosen, the <SEL> key is used to display the current setting for that item. The <EDT> key can be used to cycle through the options for that item. When the desired option is displayed the <OK> key can be pressed to accept the displayed option and re-display the item name.



**Example:** When in Setup follow the steps below to set Options, Filter.

- |   |
|---|
| • Press <GRP> repeatedly to display the <b>OPTION</b> group.                            |
| • Press <ITM> repeatedly to display the <b>FILTER</b> item.                             |
| • Press <SEL> to select <b>FILTER</b> and display the current setting.                  |
| • Press <EDT> to cycle through the options for that item.                               |
| • Press <OK> or <ITM> to accept the displayed option and re-display the menu item name. |

## 5. Basic Operation

In the most basic configuration, the instrument provides a simple weight readout.

### 5.1. Display and Controls



Figure 14: Display and Controls Illustration

#### 5.1.1. Front Panel: Visual Display

The front panel has a six-digit LCD display. Figure 14 shows the main elements of the front panel. The instrument has various main display sections for the visual output of weight information. Each display section is described below.

- Weight Display**  
 The Weight Display indicates the weight readings, setup information, errors and warnings.
- Units Display**  
 The Units Display shows the units of the weight reading as either grams (g), kilograms (kg), pounds (lb), tons (t) or none ( ). If the instrument is set up for counting the units display will show pieces (p).
- Status Annunciators**  
 Status annunciators show the following:

Table 1: Status Annunciators

Symbol	Name	Description
➡ 0 ⬅	ZERO	Visible when the gross reading is within $\pm \frac{1}{4}$ of a division of true zero.
NET	NET	Visible when the displayed reading represents NET weight.
~	MOTION	Visible when the displayed reading is not stable.
▲	OVER	Visible when the setpoint weight is over the setpoint target.
▼	UNDER	Visible when the setpoint weight is under the setpoint target.
┌	ZERO BAND	Visible when the displayed weight is within the zero 'dead' band setting. (The zero band symbol shows near the top right corner of the display.)
⏸	HOLD	Visible when the displayed reading is held.
🔋	LOW BATTERY	Visible when battery voltage is too low and batteries need replacing or recharging. (The low battery symbol shows in the top right corner of the display.)

When in Setup the editing annunciators are shown to identify the function of the front panel keys (ie. GRP, ITM, SEL, EDT and OK). For more information refer to Editing Annunciators page 12.

## 5.2. Operation Keys

The instrument has the following operation keys:

<ul style="list-style-type: none"><li>• POWER</li></ul>
<b>Primary Operation Keys</b> <ul style="list-style-type: none"><li>• ZERO</li><li>• TARE</li><li>• GROSS/NET</li><li>• PRINT</li><li>• FUNCTION (user defined)</li></ul>

Each of the primary operation keys has two separate functions.

### 5.2.1. Primary Function

A single press of each key triggers the weighing operation printed on it. The instrument allows individual keys to be disabled in the setup. All keys are enabled at the factory, but some keys may have been intentionally disabled (locked) during installation. If a key has been locked, a long beep sounds when it is pressed. If however, the key beeps normally, but does not appear to trigger the desired action, it is waiting for the weight reading to settle before the action can proceed.

### 5.2.2. Editing Function

Available during digital setup and calibration. This function is displayed using the editing annunciators above each key. Refer to Editing Annunciators page 12.

## 5.3. Stability Considerations

Once a <ZERO>, <TARE> or <PRINT> key is pressed the instrument waits for a stable valid reading before performing the associated operation. If the weight readings remain unstable or invalid due to some diagnostic error for longer than 10 seconds, the operation is cancelled and the **STABLE ERROR** message is displayed.

To improve the stability of the weight reading, increase the filtering or relax the motion detection criteria. Refer to FILTER (Reading Average) page 22 and MOTION (Motion Detection) ⊗ page 22 for more information.

## 5.4. POWER Key



The <POWER> key is used to turn the instrument on and off. To initially turn the instrument on, press and hold the <POWER> key. The display will show the following:

- Display segments will light and then clear.
- Software Version (eg. V1.0).
- Calibration Counter (eg. C.00010). Refer to Calibration Counter page 18 for more information.
- The current weight will then display.

To turn the instrument off, press and hold the <POWER> key for three seconds. The instrument will display **OFF** followed by the three-second countdown.

When using batteries the backlight will automatically turn off to conserve power after a short period of inactivity. A short press of the <POWER> key will turn the backlight on again. Refer to B.LIGHT (Backlight Operation) page 24 for more information.

**Note:** The <POWER> key can be locked to prevent the instrument being turned off from the front keypad. Refer to KEY.LOC (Front Panel Key Locking) page 24 for more information.

### 5.4.1. Automatic Operation

The <POWER> key on the instrument is unusual in that it has a memory function associated with it. This means that the state of the power setting is remembered even if external power is interrupted. It is therefore possible to turn the instrument on in the safe knowledge that it will operate whenever external power is available and will not need to be manually turned on again if the power is interrupted.

## 5.5. ZERO Key



When an empty scale has drifted away from a true zero reading, this key is used to perform a zero adjustment on the scale display. The zero adjustment is stored when power is removed and is re-used when next powered up.

The amount of weight that may be cancelled by the <ZERO> key is limited via an item in the Setup of the instrument. Refer to Z.RANGE (Allowable Zero Operating Range) ⊗ page 22 for more information.

**Long Press:** When the indicator is set to Industrial mode a long press of the <ZERO> key will remove any stored zero adjustment. Refer to Industrial vs OIML and NTEP Modes page 18 for more information on modes.

## 5.6. TARE Key



This key is used to temporarily set the scale to zero (such as cancelling the weight of a carton before performing a filling operation). The display will show the Net weight and the NET annunciator will be lit.

The <TARE> key can operate in all modes (ie. Industrial, OIML and NTEP). Refer to Industrial vs OIML and NTEP Modes page 18 for more information.

The weight tared is deducted from the allowable range of the scale, reducing the maximum weight that can be displayed.

The tare adjustment is stored when power is removed and is re-used when next powered up.

## 5.7. GROSS/NET Key



This key toggles the weight display between the Gross weight and the Net weight (provided that a Tare has previously been acquired using the <TARE> key).

### 5.7.1. GSE-LINK Activation

This feature is used to temporarily connect a PC to the instrument for calibration and setup purposes.

A long press of the <GROSS/NET> key will toggle the GSE-LINK infrared communications On/Off.

When the GSE-LINK has been (enabled) the following will occur:

- The instrument briefly displays the prompt **rin-L**.
- The editing annunciators (i.e. GRP, ITM, etc.) will flash for up to five minutes while the instrument searches for activity. During this period, the instrument also disables the RS-232 communications.
- **Activity Located:** If the instrument is **successful** in locating activity, the editing annunciators will continue to flash during the entire period of communications.
- **No Activity Located:** If the instrument **fails** to locate activity, the GSE-LINK will be disabled and the editing annunciators will stop flashing. The instrument will also revert back to the normal RS-232 communications (i.e. the SERIAL:TYPE setting will be re-activated).

## 5.8. PRINT Key



If a printer or computer has been attached to the instrument and the manual print function has been selected, the <PRINT> key will trigger an output of the current weight reading. The **PRINT** prompt is displayed while waiting for the printer to accept data. If the printer is offline the **PRINT** prompt will remain for a maximum of 10 seconds before the operation is cancelled. Each weight printed is automatically added to an internal Total Weight.

**Long Press:** A long press of the <PRINT> key will print the total. The total weight is then cleared automatically.

## 5.9. FUNCTION Key



When leaving the factory, the <FUNCTION> key is blank and has no primary function pre-programmed. The primary function of this key can be selected from a number of different functions including peak-hold, counting, etc. Refer to Special Functions page 34 for details of the available functions. Each primary function has an associated overlay sticker that should be applied to the <FUNCTION> key to label the function of the key.

**Long Press:** A long press of the <FUNCTION> key may be used for certain functions depending on the primary function of the key.

## 6. Configuration Issues

### 6.1. General Setup Information

Configuration and calibration can be performed entirely from the front panel, using the digital setup facility. When **Full Setup** is used, all menu items are accessible and care must be taken to ensure no accidental changes are made to calibration and trade settings. In addition, there is also **Safe Setup** that provides restricted access. This setup method ensures that only settings that are not calibration or trade sensitive can be changed. Full and Safe Setup can be passcode protected to prevent unauthorized or accidental tampering. If the scale has been passcode protected, the setup menus cannot be accessed until the correct code has been entered.

### 6.2. Basic Weighing Terminology

The following terms are used throughout the setup procedure. Knowledge of these basic weighing terms is beneficial in setting up and calibrating the instrument.

**Note:** Descriptions of these and other terms used in this manual are listed in the Glossary Terms page 40.

Term	Definition
Units	Units of measurement (kilograms, tons, pounds, etc.).
Full Scale	Total change in weight between zero gross load and full capacity gross load.
Resolution or Count-by	Smallest change in weight units that the display can show.
Total Number of Graduations	Maximum number of display steps between zero gross load and full capacity gross load. It is equal to full scale divided by the count-by.
Division	A single graduation.

#### Example

This example provides a check to ensure the capability of an indicator to read a stable weight on extremely small divisions compared to the load cell capacities.

The check is to find out what the micro-Volt per division is and then compare this to GSE Scale System's specification. If GSE Scale System's specification is smaller than the calculated value, the unit is within the requirements of operation.

**Note:** The capability of an indicator may be different than the trade approval limit of the micro-Volt per division.

A 10,000lb 2.0mV/V load cell is used in an application requiring a 5000lb full scale, with weight displayed in 5lb increments.

The values are:

- Units = lb
- Full Scale = 5000
- Count-by = 5

Calculating the total number of graduations:	$\text{Total Number of Graduations} = \frac{\text{Full Scale}}{\text{Count-by}} = \frac{5000}{5} = 1000 \text{ divisions}$
Signal voltages can be calculated as follows:	
Calculating the full scale signal (load cell):	$\text{Full Scale Signal} = \frac{\text{Full Scale}}{\text{Load Cell Capacity}} = \frac{5000}{10000} \times 2.0\text{mV/V} = 1.0\text{mV/V}$
Since the instrument uses 5V load cell excitation, the absolute signal voltage is:	$\text{Absolute Signal Voltage} = \text{Excitation Voltage} \times \text{Full Scale Signal} = 5\text{V} \times 1.0\text{mV/V} = 5.0\text{mV}$
Calculating the signal resolution:	$\text{Signal Resolution} = \frac{\text{Absolute Signal Voltage}}{\text{Number of Graduations}} = \frac{5.0\text{mV}}{1000 \text{ divisions}} = 0.005\text{mV} / \text{division} = 5\mu\text{V} / \text{divisor}$

### 6.3. Filtering Techniques

There is a trade off between noise filtering and the step-response time of the system. The step-response is defined as the time between placing a weight on the scale and the correct stable weight reading being displayed. This does not affect the number of readings per second that are taken. It simply defines the amount of time that is required to determine a final weight reading.

The **FILTER** setting in the instrument setup shows the amount of time over which the averaging is taken. Increasing the averaging time will result in a more stable reading but will extend the time it takes the instrument to settle to a final reading. Refer to FILTER (Reading Average) page 22.

### 6.4. Industrial vs OIML and NTEP Modes

The instrument may be operated in Industrial, OIML or NTEP mode. (**Note:** For NSC requirements, use the OIML setting.) The OIML and NTEP modes restrict certain aspects of the operation of the instrument to ensure compliance with the respective trade certified standards. For more information refer to the Calibration Counter section below and also to the USE (Scale Use) ⊗ section page 22 for setup information. The following table lists the operation differences for each of these modes.

**Table 2: Industrial vs OIML and NTEP Modes**

Element	Industrial	OIML	NTEP
<b>Underload</b>	-105% of full scale	-1% or -2% of full scale depending on zero range setting	Same as OIML
<b>Overload</b>	105% of full scale	Full scale +9 divisions	105% of full scale
<b>Tare</b>	No restrictions on Tare	Tare values must be > 0	Tare values must be > 0 and rounded to the nearest graduation
<b>Test Modes</b>	Unlimited time allowed	Limited to five seconds	Limited to five seconds

### 6.5. Calibration Counter

Within Setup there are a number of critical steps that can affect the calibration and/or legal for trade performance of the instrument. If any of these steps are altered, the trade certification of the scale could be voided.

The instrument provides built-in calibration counter(s) to monitor the number of times the critical steps are altered. The value of a counter is stored within the instrument and can only be reset at the factory. Each time a critical step is altered, the counter will increase by one. Whenever the instrument is powered up, or setup mode is entered/exited, the current value in the counter is displayed briefly (e.g. C00010).

**Note:** When the Scale Use is set to NTEP two counters will display. Refer to USE (Scale Use) ⊗ page 22 for setup information. The table below describes when the counter(s) will increment for Industrial, OIML or NTEP modes.

Industrial	OIML	NTEP
The <b>Calibration Counter</b> increments when trade critical settings, marked with ⊗, are changed. An example of the counter is <b>C.00019</b> .	The <b>Calibration Counter</b> increments when trade critical settings, marked with ⊗, are changed. An example of the counter is <b>C.00019</b>	The <b>Calibration Counter</b> increments when trade critical settings in the Calibration ( <b>CAL</b> ) menu, marked with ⊗, are changed. An example of the counter is <b>C.00010</b> .  The <b>Configuration Counter</b> increments when other trade critical settings (ie. <b>not</b> in the <b>CAL</b> menu), marked with ⊗, are changed. An example of the counter is <b>F.00009</b> .

The value(s) of the counter(s) is written on the tamperproof trade label on the front of the indicator for trade-certified applications and functions as an electronic seal. If any legal for trade settings are changed on the instrument, the current value of the calibration counter will be different from the recorded value and the seal is broken. In this manual, items marked with ⊗ indicate that the setting is legal for trade critical settings.

## 6.6. Passwords

The instrument has two levels of passcodes to provide a security lock on accessing Setup via the keypad.

- Full Setup Passcode
- Safe Setup Passcode

The Full Setup passcode can also be used to access Safe Setup.

### 6.6.1. Full Setup Password

Setting a passcode for Full Setup restricts any access to Full Setup. Refer to FULL.PC (Full Security Passcode for Digital Setup) page 23.

### 6.6.2. Safe Setup Password

Setting a passcode for Safe Setup restricts access to Safe Setup functions. Refer to SAFE.PC (Safe Security Passcode for Digital Setup) page 23.

### 6.6.3. Setup Lock-Out

If an attempt is made to enter Full or Safe Setup using an incorrect passcode, the instrument will respond with the message **ENTRY DENIED** and then the user will be returned to normal operating mode. A passcode counter has been set so that only three failed attempts can be made to access Full/Safe Setup. On the fourth attempt the user will be 'locked out' of Full/Safe setup. Should this occur the **ENTER PASS** prompt will not display, but instead the **ENTRY DENIED** message displays and returns the user to the normal operating mode.

To rectify this issue the instrument must be turned off. When the instrument is turned back on the passcode counter is reset to zero (allowing the user to enter the correct passcode).

## 7. Setup

The instrument digital setup facilities provide the means to configure and calibrate the instrument.

### 7.1. Accessing Setup

There are two methods to access the Setup area. For further details of menu items available in each setup mode, refer to the Setup Menu Quick Reference page 38.

- The **Full Setup** method provides access to all functions in Setup, including legal for trade and calibration sensitive settings. Changes in Full Setup mode may result in the calibration counter being incremented. Items marked with ⊗ indicate that the setting is trade critical. Changes to passcodes and restoring the factory default settings can only be accessed in Full Setup mode. These items will however not increment the calibration counter. If an attempt is made to enter Full Setup using the incorrect passcode, the instrument will respond with the message **ENTRY DENIED**. Refer to Passwords page 19 for more information.

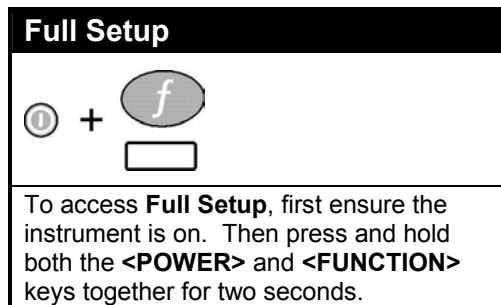

### WARNING

All items in all menus will be enabled in **Full Setup**. Care should be taken to avoid inadvertently altering the Build or Calibration settings.

- The **Safe Setup** method restricts access to the Trade Critical settings. Changes made in this mode will not increment the calibration counter. In this manual, items marked with ⊗ indicate that the setting is trade critical. If an attempt is made to enter Safe Setup using the incorrect passcode, or if an attempt is made to alter a trade critical setting while in Safe Setup, the instrument will respond with the message **ENTRY DENIED**. Refer to Passwords page 19 for more information.

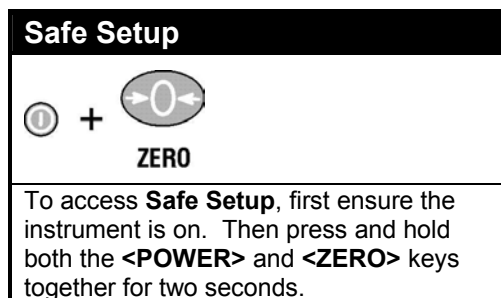

#### 7.1.1. Setup Display Prompts

When accessing **Full** or **Safe Setup** the instrument will beep twice and then display the following:

- FULL or SAFE (depending on setup access type)
- SETUP
- Software Version (e.g. V1.0)
- Calibration Counter (e.g. C.00010). Refer to Calibration Counter page 18 for more information.
- If a passcode has been configured, the **ENTER PASS** prompt will display and the setup passcode must be entered to gain access. Refer to Passwords page 19, **SAFE.PC** (Safe Security Passcode for Digital Setup) page 23 and **FULL.PC** (Full Security Passcode for Digital Setup) page 23 for more information.
- The title of the first Group (i.e. **BUILD**) will then be displayed.

### 7.2. Exiting Full or Safe Setup

To save settings, exit setup and return to the normal weighing mode use one of the following methods:

- |   |
|---|
| • <b>Method 1:</b> Press and hold both the <b>&lt;POWER&gt;</b> and <b>&lt;FUNCTION&gt;</b> keys together for two seconds.                    |
| • <b>Method 2:</b> Press and hold both the <b>&lt;POWER&gt;</b> and <b>&lt;ZERO&gt;</b> keys together for two seconds.                        |
| • <b>Method 3:</b> Press the <b>&lt;GRP&gt;</b> key repeatedly. When <b>- End -</b> displays press <b>&lt;ITM&gt;</b> or <b>&lt;ITM&gt;</b> . |



The instrument will beep and then display the following:

- SAVING
- Software Version (e.g. V1.0)
- Calibration Counter (e.g. C.00010). Refer to Calibration Counter page 18 for more information.
- The current weight will then display.

**Warning:** If the power is interrupted while in setup (ie. by disconnecting the power cable or pressing the <POWER> key), unsaved settings will be lost.

## 7.3. Groups and Items

All keypad setup options in the instrument are organized in a tree structure made up of **Groups** and **Items**. To simplify this document, Groups and Items will be notated as follows (GROUP:ITEM). Refer to Setup Menu Quick Reference page 38 for a list of all Groups and Items.

### 7.3.1. GRP (Group)

Setup is divided into a series of **Groups**. Each group has a distinctive group title. All options in any one group have related functions. The <GRP> key can be used to cycle through the available groups.

### 7.3.2. ITM (Item)

Each group is divided into individual **Items**. Each item represents a parameter that can be changed. Pressing the <ITM> key will enter the displayed group, allowing access to the items within the group. The <ITM> key can be used to cycle through the available items. The <SEL> key is then used to edit the item.

## 7.4. Setup Menus

The following sections describe the setup parameters of each of the Groups and Items in Setup.

### 7.4.1. BUILD (Scale Build)

Settings within this Group are used to configure the indicator to suit the current application. It is important to fully set the options within this group before calibration is attempted. Later changes to items within this group may invalidate the current calibration data.

- **DP (Decimal Point Position) ⊗**  
Sets the location of the decimal point on the display. To avoid confusion, set this parameter first so that all other weight related values are displayed with the decimal point in the correct position.
  - Can be set from 000000 (none) to 0.00000
  - Default: 000000
- **CAP (Maximum Capacity) ⊗**  
Sets the nominal maximum capacity (or full scale) of the scale. This is set in weighing units (e.g. lb, t, etc.), with the decimal point in place. For example, if a scale is to weigh 500.0 lb in 0.5 lb increments, CAP is set to 500.0, and RES is set to 5.
  - Range: 000100 to 999999
  - Default: 003000
- **RES (Count-by Resolution) ⊗**  
Sets the resolution (or Count-by) of the display. The resolution is the number by which the indicator will count.
  - Options are: 1, 2, 5, 10, 20, 50 or 100
  - Default: 1
- **UNITS (Weighed Units) ⊗**  
Sets the units for display and printing.
  - Options are: (g) grams, (kg) kilograms, (lb) pounds, (t) tons, ( ) none (i.e. other units).
  - Default: kg
- **HI.RES (High Resolution x 10 mode) ⊗**  
Sets the instrument to display weight at 10 times resolution. This is intended for test purposes but may be used for non-trade weighing.

- Options are: ON or OFF
- Default: OFF
- **CABLE (4-Wire or 6-Wire) ⊗**  
Sets the load cell input to operate in 4-wire (auto sense) or 6-wire mode.
  - Options are: 4 or 6
  - Default: 6

#### 7.4.2. OPTION (Scale Options)

Items within this Group are used to configure the operating parameters of the scale.

- **USE (Scale Use) ⊗**  
This is where the basic use of the scale is set. This setting configures the instrument for Industrial, OIML or NTEP operation. Refer to Industrial vs OIML and NTEP Mode page 18 for more information.
  - Options are: INDUST (Industrial), OIML or NTEP
  - Default: INDUST
- **FILTER (Reading Average)**  
The instrument can average a number of consecutive readings when calculating the displayed weight. This is used to dampen unwanted weight fluctuations caused by vibrations or dynamic forces. High settings will stabilize the display at the expense of rapid response to sudden weight changes.
  - Options are: NONE, 0.2, 0.5, 1.0, 2.0, 3.0, 4.0 (time in seconds)
  - Default: 0.5 (seconds)
- **MOTION (Motion Detection) ⊗**  
Sets how much weight variation over a defined time period is allowed before the displayed weight is deemed to be unstable. This value is displayed as weight change (0.5 or 1.0 graduations) per second. When set to **OFF**, the Motion Detection is ignored and ZERO, TARE and PRINT actions are instantaneous.
  - Options: OFF, 0.5-1.0, 1.0-1.0 (graduations per second)
  - Default: 0.5-1.0 (0.5 graduations per second)
- **INIT.Z (Initial-Zero on Startup)**  
This function can be used to automatically ZERO the indicator during power-up. The amount of weight that can be zeroed is limited to +/- 10% of full scale.
  - Options are: ON or OFF
  - Default: OFF
- **Z.TRAC (Zero Tracking Sensitivity) ⊗**  
Zero tracking allows the display to adjust for minor changes in the zero balance of the scale. When enabled, the instrument will track weight readings within the zero 'dead' band back to exactly zero at a maximum rate of 0.5 (SLOW) or 10 (FAST) graduations per second.
  - Options are: OFF, SLOW, FAST
  - Default: OFF
- **Z.RANGE (Allowable Zero Operating Range) ⊗**  
This setting restricts the range over which the Zero functions can operate.
  - Options are: -2\_2, -1\_3, -20\_20
  - Default: -2\_2 (-2% to +2%)
- **Z.BAND (Zero 'Dead' Band) ⊗**  
This is an adjustable margin either side of true zero that defines the zero 'dead' band. The zero 'dead' band is used by the automated functions to determine zero load (e.g. a setting of 4 specifies that readings between -4.5 and 4.5 are considered to be zero). When the displayed weight reading is within this band the instrument displays the **zero band** annunciator. Refer to Status Annunciators page 14.
  - Settable over the full weight range. Always enter a number in multiples of display units. Refer to RES (Count-by Resolution) ⊗ page 21 for more information.

- Default: 0 (i.e. –0.5 to 0.5 graduations)

### 7.4.3. CAL (Scale Calibration)

Items within this group perform various calibration routines. For detailed scale calibration procedures refer to Calibration page 28. Certain items in the Scale Build can affect the calibration of the scale. Always check that these sections are correctly configured to suit the current application before attempting to calibrate the scale.

- **ZERO (Zero Calibration) ⊗**  
Select to perform Zero Calibration. While the zeroing is in progress the display will show **Z.in P.** Refer to ZERO (Zero Calibration Routine) page 29.
- **SPAN (Span Calibration) ⊗**  
Select to perform Span Calibration. While the span calculation is in progress the display will show **S.in P.** Refer to SPAN (Span Calibration Routine) page 29.
- **ED.LIN (Edit Linearization Points) ⊗**  
Select to view linearization setup and start linearization routines. While linearization is in progress the display will show **L.in P.** Refer to ED.LIN (Edit Linearization Points) page 30 for more information.
- **CLR.LIN (Clear Linearization Points) ⊗**  
Select to view linearization setup and select linearization points to clear. Refer to CLR.LIN (Clear linearization) page 30 for more information.
- **DIR.ZER (Direct Zero Calibration) ⊗**  
Select to enter the mV/V value of the zero calibration directly. This feature is used to enable approximate calibrations to be performed in situations where a standard ZERO calibration is impractical (e.g. calibration on a partially filled silo).
- **DIR.SPN (Direct Span Calibration) ⊗**  
Select to enter the mV/V value of the full scale capacity of the scale build. This feature enables the instrument to be calibrated based on the rated output capacity of the load cells rather than using test weights. The accuracy of this method is limited to the accuracy of the published load cell ratings.
- **FAC.CAL (Restore Default Factory Calibration) ⊗**  
Select this choice to restore default factory calibration. This restores all calibration critical settings in the **BUILD**, **OPTION** and **CAL** menus back to factory defaults. The instrument will prompt with **Cont. N.** Press **<EDT>** to change to **Cont. Y** and **<OK>** to continue. If **Cont. Y** is chosen and then **<OK>** or **<ITM>** is pressed, the instrument will display **DONE** to indicate that the operation has been completed.

### 7.4.4. SPEC (Special Settings Menu)

Settings within this group control features including passcodes, key locking, key functions and display settings.

- **SAFE.PC (Safe Security Passcode for Digital Setup)**  
The **SAFE.PC** (Safe Passcode) allows partial access to Digital Setup (ie. only non calibration/trade critical settings can be changed). For the Safe Passcode to have any effect, the **FULL.PC** passcode must also be set. The default passcode setting is **000000** that allows free access. Any other number will enable the passcode functions and restrict access. Refer to Passwords page 19 and Accessing Setup page 20 for more information.
  - Range 000000 to 999999
  - Default: 000000
- **FULL.PC (Full Security Passcode for Digital Setup)**  
The **FULL.PC** (Full Passcode) can be set to restrict access to Full Digital Setup. This passcode is used to prevent unauthorized or accidental tampering in the instrument setup. The default passcode setting is **000000** that allows free access. Any other number will enable the passcode functions and restrict access. Refer to Passwords page 19 and Accessing Setup page 20 for more information.

- Range 000000 to 999999
- Default: 000000

It is important to note that when restricting Full access to Setup the passcode must not be forgotten. It is only possible to circumvent the passcode at the factory. Care must be taken when setting the Full Digital Setup Passcode to ensure that the instrument does not become permanently locked.

- **KEY.LOC (Front Panel Key Locking)**

This item allows individual keys to be locked and unlocked. The display shows a dash (–) to indicate that a key is locked (inactive) or characters for each key that is active (ie. the characters **P12345** display). The letter **P** represents the **<POWER>** key and the numbers **1234** and **5** represent the remaining operation keys. The operation keys are numbered from the left with the **<ZERO>** key being number 1.

**Note:** When the **<POWER>** key is locked, the instrument cannot be turned off from the front keypad.

- Default: P12345 - All keys are unlocked (active)

- **KEY.FN (Key Functions)**

The function of the keypad **<FUNCTION>** key can be selected here. Refer to Special Functions page 34 for details of the available key functions.

Options are:

• NONE	• COUNT	• HOLD	• LIVE.WT
• TEST	• UNITS	• PEAK.H	• SHOW.T

- Default: NONE

- **AUT.OFF (Auto Power Off / Battery Operation)**

The instrument can be set up to automatically power down after a period of no activity. Weight motion, network communications or any press of the keyboard is enough to keep the instrument powered on. When operating on batteries the instrument will turn off after 30 minutes of inactivity even if set to NEVER.

Options are:

- NEVER: Never power off automatically (Battery: powers down after 30 minutes)
- 1, 5, 10 (time in minutes)
- Default: NEVER

- **B.LIGHT (Backlight Operation)**

Sets the operation of the backlight. When operating the backlight with batteries the brightness is lowered automatically to conserve power and the backlight will automatically turn off after 10 seconds of inactivity. To turn on again, press the **<POWER>** key.

Options are:

- OFF: Backlight is off
- ON: Backlight is always on
- Default: ON

- **REM.FN (Remote Function)**

This item allows the indicator to be triggered from a remote input. The remote input can be set to have no function (i.e. NONE) or it can be set to mimic one of the front five panel key functions (i.e. where KEY1=ZERO, KEY2=TARE, KEY3=GROSS/NET, KEY4=PRINT and KEY5=FUNCTION).

The remote input can also be set to BLANK where, when the remote input is pressed and held, the indicator displays dashes (i.e. - - - - -) and the front five key functions are disabled. When the remote input is released the indicator display and front key functions return to normal.

For the REM.FN to have any effect, the SERIAL:TYPE item must be set to KEY. Refer to TYPE (Serial Output Type) below for more information.

Options are:

- NONE: No function.
- KEY1 to KEY 5: Mimic one of the front five function keys
- BLANK: Display dashes (i.e. - - - - -) and disable front key functions.

- Default: NONE

#### 7.4.5. SERIAL (Serial Communications Options)

Settings within this Group determine the serial and printing outputs. Refer to Serial Outputs page 31 for more information on Serial configuration.

- **TYPE (Serial Output Type)**

Sets the function of the first serial output. The port can be disabled or set to run as an automatic output or a network device.

Options are:

- NET: Network Communications.
- AUTO.1: Enables 10 Hz automatic transmission using format 1.
- AUTO.2: Enables 10 Hz automatic transmission using format 2.
- PRINT: Enables printer driving.
- MASTER: Send contents of LCD display to a remote display.
- KEY: Enables the Remote Function setting (SPEC:REM.FN).
- Default: NET

- **BAUD (Serial Baud Rate)**

The baud rate determines the serial data transmission speed.

- Options are: 2400, 4800, 9600
- Default: 9600

- **BITS (Serial Format Options)**

The Bits options allow the data transmission bit pattern and interface to be changed. The display will show the current setting in the form **n81-** where each character has a meaning as shown below.

Options are:

- N or O or E: Parity bit: (N) None, (O) Odd, (E) Even
- 8, 7: Number of data bits
- 1, 2: Number of stop bits
- -, D: DTR handshake disabled or enabled
- Default: n81-. (For most applications the default setting is applicable.)

- **ADDRES (Instrument Address)**

Use this option to set the instrument address when operating with network communications.

- Range 01 to 31
- Default: 31

- **RST.CON (Reset Printed Consecutive Number) ⊗**

Use this option to reset the printed consecutive number back to 1. The instrument will prompt with **Cont. N**. Press **<EDT>** to change to **Cont. Y** and **<OK>** to continue. When **Cont. Y** has been chosen the instrument will display **DONE** to indicate that the operation has been completed.

#### 7.4.6. SET.PTS (Setpoint Settings)

Settings within this group configure the setpoint system. Refer to Setpoints page 33 for a detailed explanation of setpoints.

- **SRC (Weight Source)**

The weight source determines the weight reading that is used for the setpoint comparisons.

Options are:

- GROSS: Use gross weight readings always.
- DISP: Use the displayed weight (gross or net).
- OFF: Both setpoints are off.
- Default: OFF

- **TARG.HI (Target for Overweight)**

This is the target for setpoint 1 (output 1). Weights above this target will cause the setpoint to become active and output 1 to be driven. The instrument displays the **over** annunciator. Refer to Status Annunciators page 14.

- Range: -99999 to 999999
- Default: 000000

- **TARG.LO (Target for Underweight)**

This is the target for setpoint 2 (output 2). Weights below this target will cause the setpoint to become active and output 2 to be driven. The instrument displays the **under** annunciator. Refer to Status Annunciators page 14.

- Range: -99999 to 999999
- Default: 000000

#### 7.4.7. CLOCK (Clock Settings)

Items within this group set date and time related functions.

- **FORMAT (Date Format)**

This sets the date format.

Options are:

- dd.mm.yy
- mm.dd.yy
- Default: dd.mm.yy

- **YEAR (Set Year)**

- Range: 2000 to 2099

- **MONTH (Set Month)**

- Range: 01 to 12

- **DAY (Set Day)**

- Range: 01 to 31

- **HOUR (Set Hour)**

- Range: 00 to 23 (24-hour format)

- **MINUTE (Set Minute)**

- Range: 00 to 59

#### 7.4.8. TEST (Special Test Functions)

Items within this Group allow access to the testing routines for the instrument. With these routines the scale base output can be monitored and the inputs and outputs can be tested.

- **SCALE (Scale Base Test Display)**

Verifies the correct load cell capacity and/or load cell wiring is used. It sets up the instrument as a simple test meter to measure the load cell signal output. The display reads in milliVolts-per-Volt, factory calibrated to 0.1% worst case. When accessing this item, initially there should be no weight on the scale. In OIML or NTEP modes, this display is only active for five seconds before returning to the menu.

- **FRC.OUT (Force Outputs)**

Forces each of the output drivers in turn. All outputs turn OFF when leaving this step. The <EDT> key will advance through each output (i.e. ON.1 and ON.2). Pressing <OK> will turn all outputs off and exit the test.

#### 7.4.9. FACTRY (Factory Adjustment Menu)

- **DEFLT (Restore Factory Settings Except for Calibration and Build)**

Restores all settings in the digital setup, which are not calibration critical back to the original **new** settings installed at the factory. The main use of this routine is to completely reset an instrument that is being installed on a different scale. The instrument will prompt with **Cont. N**. Press **<EDT>** to change to **Cont. Y** and **<OK>** to continue. When **Cont. Y** has been chosen the instrument will display **DONE** to indicate that the operation has been completed.

Restoring the factory options does not affect the calibration. To reset the calibration to factory condition CAL:FAC.CAL must be used. Refer to FAC.CAL (Restore Default Factory Calibration) ⊗ page 23. This menu item is only available when in Full Digital Setup mode.

#### 7.4.10. – End – (Leaving Setup)

Refer to Exiting Full or Safe Setup page 20.

## 8. Calibration

The calibration of the indicator is fully digital. The calibration results are stored in permanent memory for use each time the instrument is powered up.

**Note: Some of the digital setup steps can affect calibration. The BUILD and OPTION settings MUST be configured before calibration is attempted.**

To perform a calibration, when in Full Setup select the **CAL** Group using the **<GRP>** key.

The calibration program will automatically prevent the instrument from being calibrated into an application outside of its specification. If an attempt is made to calibrate outside of the permitted range, an error message will display and the calibration will be abandoned. Refer to Error Messages page 39.

The instrument has a wide-range ADC. The non-trade calibration range of the instrument extends well beyond the Trade approved range.

**Note: It should not be assumed that just because the instrument has successfully calibrated a scale, that the scale is correct for trade use. Always check the scale build against the approval specification.**

### 8.1. Performing a Digital Calibration with Test Weights

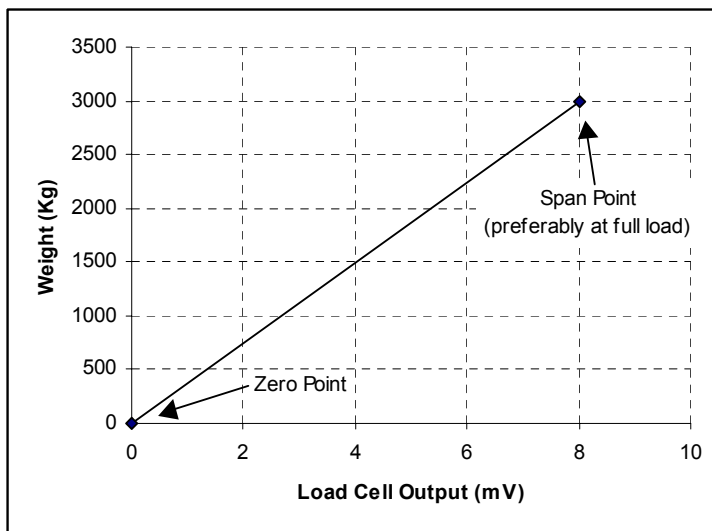

**Figure 15: Chart - Zero and Span Points to Interpolate Weight from Load Cell**

The Zero setting (CAL:ZERO) specifies a gross zero point for the scale. The Span setting (CAL:SPAN) specifies a second point (**preferably close to full scale**) used to convert the A/D readings into weighing units (e.g. kg). Select either of the Zero (CAL:ZERO) or Span (CAL:SPAN) calibration items. It is important that an initial Zero calibration is performed before any SPAN calibrations. The chart shown here demonstrates how the zero and span points are used to interpolate a weight reading from the load cell reading.

**Note: Calibration points (Zero, Span and Linearization) must be spaced by at least 2% of Full scale from each other.**



### 8.1.1. ZERO (Zero Calibration Routine)

- |  |
|--|
| <ul style="list-style-type: none"><li>• Press the &lt;SEL&gt; key to start. The display will show the current weight. Remove all weight from the scale structure.</li></ul>  |
| <ul style="list-style-type: none"><li>• Press &lt;SEL&gt;, &lt;EDT&gt; or &lt;OK&gt; to execute a Zero Calibration. The display will show <b>Z.in.P</b> to indicate that zeroing is in progress. When the process is complete the display will return to weight to allow the zero to be checked.</li></ul> |
| <ul style="list-style-type: none"><li>• Press the &lt;ITM&gt; key to leave the Zeroing routine or press &lt;SEL&gt;, &lt;EDT&gt; or &lt;OK&gt; to repeat the operation.</li></ul>  |

### 8.1.2. SPAN (Span Calibration Routine)

- |  |
|--|
| <ul style="list-style-type: none"><li>• Press &lt;SEL&gt; or &lt;OK&gt; to start. The display will show the current weight.</li></ul>  |
| <ul style="list-style-type: none"><li>• Add the calibration test mass to the scale. The minimum acceptable span calibration weight is 2% of the scale range. A weight this small may limit calibration accuracy. The closer the test weight is to full scale the better the accuracy.</li></ul>                        |
| <ul style="list-style-type: none"><li>• Press &lt;SEL&gt; or &lt;OK&gt; to show the calibration weight value. Change this to the correct calibration weight using the &lt;SEL&gt; and &lt;EDT&gt; keys.</li></ul>  |
| <ul style="list-style-type: none"><li>• Press &lt;ITM&gt; or &lt;OK&gt; to trigger the Span Calibration routine. The display will show <b>S.in P</b> to indicate that spanning is in progress. When the process is complete the display will return to weight to allow the new weight reading to be checked.</li></ul> |
| <ul style="list-style-type: none"><li>• When the Span Calibration is complete, press the &lt;ITM&gt; key to leave the Spanning routine or press &lt;SEL&gt;, &lt;EDT&gt; or &lt;OK&gt; to re-edit the calibration weight and repeat the operation.</li></ul>   |

## 8.2. Performing a Calibration with Direct mV/V Entry

In applications where test weights are not easily available, it is possible to calibrate the instrument directly by entering the mV/V signal strength at Zero and full scale Span. The Direct Zero setting (CAL:DIR.ZER) specifies a gross zero point for the scale. The Direct Span setting (CAL:DIR.SPN) specifies the mV/V signal strength corresponding to an applied mass equal to the full scale reading. This calibration technique is not compatible with linearization. Clearly the accuracy of this type of calibration is limited to the accuracy of the direct mV/V data.

### 8.2.1. DIR.ZER (Direct Zero Calibration Entry)

- |   |
|---|
| <ul style="list-style-type: none"><li>• Press the &lt;OK&gt; key to start. The display will show the current weight.</li></ul>  |
| <ul style="list-style-type: none"><li>• Press the &lt;OK&gt; key to enter the Direct Zero setting. Change the mV/V setting to the correct value for <b>Zero</b> using the &lt;SEL&gt; and &lt;EDT&gt; keys.</li></ul>       |
| <ul style="list-style-type: none"><li>• Press the &lt;OK&gt; key to store the new zero calibration. When the process is complete the display will return to weight to allow the new weight reading to be checked.</li></ul> |
| <ul style="list-style-type: none"><li>• Press the &lt;ITM&gt; key to leave the Direct Zero routine or &lt;OK&gt; to repeat the operation.</li></ul>   |

### 8.2.2. DIR.SPN (Direct Span Calibration Entry)

- |   |
|---|
| <ul style="list-style-type: none"><li>• Press the &lt;OK&gt; key to start. The display will show the current weight.</li></ul>  |
| <ul style="list-style-type: none"><li>• Press the &lt;OK&gt; key to enter the Direct Span setting. Change the mV/V setting to the correct value for the full scale signal strength, using the &lt;SEL&gt; and &lt;EDT&gt; keys.</li></ul> |
| <ul style="list-style-type: none"><li>• Press the &lt;OK&gt; key to store the new span calibration. When the process is complete the display will return to weight to allow the new weight reading to be checked.</li></ul>               |
| <ul style="list-style-type: none"><li>• Press the &lt;ITM&gt; key to leave the Direct Span routine or &lt;OK&gt; to repeat the operation.</li></ul>   |

## 8.3. Using Linearization

This section provides instructions on the use of the linearization. Linearization is used to approximate the weight output to a non-linear scale. The chart below shows a non-linear characteristic for the load cell output. From the chart, it can be seen that the trace with no linearization applied is a poor approximation to the real characteristic. By applying one or more linearization points, more accurate weight readings can be achieved.

To perform a linearization, a calibration of the zero and full scale span points must have been performed. Both the zero and full scale calibration points are used in the linearization of the scale base. These two points are assumed to be accurately set and thus have no linearization error.

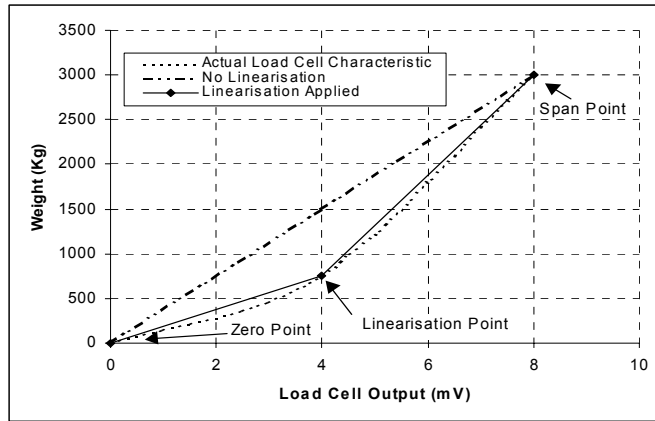

**Figure 16: Chart - Non-Linear Characteristic for Load Cell Output**

A maximum of five linearization points can be set independently between zero and full scale. Unused or unwanted points may also be cleared. The maximum correction that can be applied using a linearization point is  $\pm 2\%$ .

### 8.3.1. ED.LIN (Edit Linearization Points)

- |   |
|---|
| <ul style="list-style-type: none"> <li>Press the &lt;SEL&gt; key to step through the list of points. Each point is shown as <b>Ln.ppp</b> where <b>n</b> is the point number (1 to 5), and <b>ppp</b> is the approximate percentage of full scale where the linearization is applied. For example, <b>L1.050</b> indicates that linearization point one is active and was entered at about 50% of full scale. Unused linearization points are shown with a row of dashes (e.g. L2. - - -).</li> </ul> |
| <ul style="list-style-type: none"> <li>Press &lt;OK&gt; to change the linearization point selected or press &lt;ITM&gt; to exit without making any changes.</li> </ul>  |
| <ul style="list-style-type: none"> <li>After pressing &lt;OK&gt;, the current weight reading is displayed. Add the calibration test mass to the scale. The closer the test mass is to the point of maximum error in linearity the more effective will be the correction. Press &lt;OK&gt; to enter a corrected weight value for this point or &lt;ITM&gt; to exit without making changes.</li> </ul>  |
| <ul style="list-style-type: none"> <li>Use the &lt;SEL&gt; and &lt;EDT&gt; keys to enter the correct value of the calibration weight being used.</li> </ul>   |
| <ul style="list-style-type: none"> <li>Press the &lt;OK&gt; key to trigger the linearization routine. The display will show <b>L.in P</b> to show that linearization is in progress. When the process is complete the display will show the weight to allow the new weight reading to be checked before returning to the menus. Press &lt;ITM&gt; to leave the routine or &lt;OK&gt; to repeat the operation.</li> </ul>  |

### 8.3.2. CLR.LIN (Clear linearization)

- |  |
|--|
| <ul style="list-style-type: none"> <li>Press the &lt;SEL&gt; key to step through the list of points. Each point is shown as <b>Ln.ppp</b> where <b>n</b> is the point number (1 to 5), and <b>ppp</b> is the approximate percentage of full scale where the linearization is applied. For example, <b>L1.050</b> designates that linearization point one is active and was entered at about 50% of full scale. Unused linearization points are shown with a row of dashes (e.g. L2. - - -).</li> </ul> |
| <ul style="list-style-type: none"> <li>Press &lt;OK&gt; to choose the linearization point to clear. The indicator will prompt to continue with <b>CONT. N</b>. Press &lt;ITM&gt; to switch between <b>Cont. N</b> (No) and <b>Cont. Y</b> (Yes). The &lt;OK&gt; key is used to accept your choice. When <b>Cont. Y</b> has been chosen the cleared linearization point then displays (e.g. L1. - - -).</li> </ul>  |
| <ul style="list-style-type: none"> <li>Press &lt;ITM&gt; to return to <b>CLR.LIN</b>.</li> </ul>   |

**Note:** All linearization points are cleared by restoring the default calibration of the instrument. The zero and span settings are also cleared by this process.

## 9. Serial Outputs

The instrument can support the optional temporary GSE-LINK connection. In addition, there is a single bi-directional RS-232 output. This provides a number of serial output options allowing communications with external devices such as printers, computers, PLCs or remote displays. Refer to GSE-LINK Activation page 10. For wiring connections and pinouts, refer to Auxiliary Connection page 8.

The serial available functions include:

- Automatic Weight Output (two formats available)
- Network Communications
- Master / Slave
- Printing

All serial output options are enabled and configured using the serial communications options in the digital setup procedure. Refer to SERIAL (Serial Communications Options) page 25.

The instrument computer communications can range from simple automatic streamed output, through to a command-response system. In addition to the GSE-LINK, the instrument can be programmed and calibrated via the RS-232 serial port. The calibration counter is incremented when the calibration related steps are accessed via RS-232, the serial port or the GSE-LINK. This means that calibration via the serial port or GSE-LINK cannot be carried out without affecting the certification of a trade installation.

### 9.1. Automatic Weight Output

The automatic output is normally used to drive remote displays, a dedicated computer, or PLC communications.

#### Auto Weight Format String

The weight format string may be set to the following formats:

Format	Description
AUTO1	<STX> <SIGN> <WEIGHT(7)> <STATUS> <ETX>
AUTO2	<STX> <SIGN> <WEIGHT(7)> <S1> <S2> <S3> <S4> <UNITS(3)> <ETX>

Where

- **STX**: Start of transmission character (ASCII 02).
- **ETX**: End of transmission character (ASCII 03).
- **SIGN**: The sign of the weight reading (space for positive, dash (-) for negative).
- **WEIGHT(7)**: A seven character string containing the current weight including the decimal point. If there is no decimal point, then the first character is a space. Leading zero blanking applies.
- **STATUS**: Provides information on the weight reading. The characters G/N/U/O/M/E represent Gross / Net / Underload / Overload / Motion / Error, respectively.
- **UNITS(3)**: A three character string, the first character being a space, followed by the actual units (e.g. ^kg or ^t). If the weight reading is not stable, the unit string is sent as ^^.
- **S1**: Displays G/N/U/O/E representing Gross / Net / Underload / Overload / Error, respectively.
- **S2**: Displays M/^ representing Motion / Stable, respectively.
- **S3**: Displays Z/^ representing center of Zero / Non-Zero, respectively.
- **S4**: Displays - representing single range.

- **Printing**

The instrument has a single fixed printing format that is as follows:

```
000048 06/05/2003 15:10
                121.4 lb G
```

The first line contains a six digit sequential number that is automatically incremented with each printing, up to a maximum of 999999. The first line also contains the current date and time, printed in the selected format.

The second line shows the displayed reading, units and **G** for Gross or **N** for Net.

If counting is active, the printout has a third line for the counting information (**p** for pieces) as follows:

```
                164 p
```

Whenever a new sample is taken when counting, the instrument prints the sample as in the following format:

```
SAMPLE:      100 p =  50.0 lb
```

In addition to the printout, the instrument adds the weight and pieces printed to the internal weight and count totals. A long press of the <PRINT> key will print and clear these totals. The six digit sequential number is not cleared. Following is a sample of a total ticket:

```
000049 06/05/2003 15:20
          90.6 lb G
000050 06/05/2003 15:21
          154.9 lb G
000051 06/05/2003 15:21
          50.4 lb G
000052 06/05/2003 15:21
          71.0 lb G
000053 06/05/2003 15:21
          13.3 lb G
ITEMS:      5
TOTAL:     380.2 lb
```

If counting is active each of the individual printouts would have a third line as discussed above and the **TOTAL** would have an additional QTY line as follows:

```
000054 06/05/2003 15:22
          13.3 lb G
           27 p
000055 06/05/2003 15:23
          79.3 lb G
          159 p
000056 06/05/2003 15:23
          117.0 lb G
          234 p
ITEMS:      3
TOTAL:     209.6 lb
QTY:       420 p
```

## 9.2. Master Serial Output

In **Master** mode, the instrument sends out the entire contents of the LCD every 100msec. This is essentially the same as AUTO output but the format of the output string is designed to allow a remote display to exactly copy the contents of the LCD including all of the annunciators and user prompts, etc.

## 10. Setpoints

The instrument is capable of working with two internal setpoints. The status of these setpoints is displayed on the LCD. Each setpoint is associated with a physical output driver but it may also be simply used as an indicator.

Refer to SET.PTS (Setpoint Settings) page 25 for details on settings.

### 10.1. Setpoint Connection

Refer to Auxiliary Connection page 8 for the method of connection of the external output drivers.

### 10.2. Setpoint Operation

Setpoint 1 is configured as an overload setpoint. The SET.PTS:TARG.HI value sets the value for the overload limit. Setpoint 2 is an underload setpoint and its limit value is set by SET.PTS:TARG.LO value.

The SET.PTS:SRC setting allows the gross weight or displayed weight to be chosen as the source for the setpoint operation. This allows the overload and underload limits to be linked to gross weights always or alternatively to be linked to the current displayed weights.



When the selected weight is greater than the TARG.HI value the over annunciator is visible and output 1 is activated.



When the selected weight is less than the TARG.LO value the under annunciator is visible and output 2 is activated.

# 11. Special Functions

## 11.1. Introduction



The instrument has a special function key on the front panel. This function of this key can be configured to any of the key functions detailed below. Refer to KEY.FN (Key Functions) page 24 to configure the function key.

When leaving the factory, the <FUNCTION> key is blank and has no primary function pre-programmed. Each primary function has an associated overlay sticker (supplied) that should be applied to the function key to label the function. Ensure the keypad is clean and dry before affixing the sticker. Refer to Cleaning page 6 for more information.

## 11.2. Key Functions

### 11.2.1. NONE

When set to **NONE** the special function key is not used during normal operation. This is the default setting.

### 11.2.2. TEST

- Press the <TEST> key to clear the display then show all segments of the display then clear the display again before returning to normal operation.

### 11.2.3. COUNT

Use this key to perform pieces counting. Press the <COUNT> key to switch between weight display and counts display. The instrument annunciator shows **p** for pieces.

To record a new sample do the following:

- Tare off any containers.
- Place the sample on the scale
- Press and hold the <COUNT> key for two seconds. The default number of items in the sample will be displayed.
- Use the <SEL> and <EDT> keys to alter the number of items.
- Press <OK> and the current sample will be stored against the entered items.
- If printing is enabled the sample quantity and weight will be printed.

### 11.2.4. UNITS

Use the <UNITS> key to switch the displayed reading between **lb** and **kg**. This will affect the displayed and printed weight but will not affect any data entry. The following is a sample of a printout displaying kg and lb.

```
000009 06/05/2003 16:31
                2.8 kg G
000010 06/05/2003 16:31
                6.1 lb G
```

### 11.2.5. HOLD and PEAK HOLD

The <HOLD> key implements a manual **Hold** function. The <PEAK> key implements a **Peak Hold** function where the largest absolute weight, either positive or negative is stored in the peak value (e.g. -30 is larger than 25). The **Hold** annunciator is active when the display is showing the held weight. Refer to Status Annunciators page 14.

To perform the **Hold** function, do the following:

- Press the manual <HOLD> key once to hold the current displayed weight.
- Press the manual <HOLD> key again to return the display to normal weighing.

To perform the **Peak Hold** function do the following:

- Press the <PEAK> hold key once to show the absolute peak weight reading.
- Press the <PEAK> hold key again to return the display to normal weighing.
- A long press of the <PEAK> hold key clears the peak value back to **0** (zero).

All printouts that print the displayed weight will use the held weight reading if it is currently being displayed.

### 11.2.6. LIVE.WT

The <LIVE.WT> key is used to enable live weight averaging. With this feature, it is possible to determine the weight of a continually moving mass (e.g. livestock).

- |   |
|---|
| <ul style="list-style-type: none"><li>• Press and hold the &lt;LIVE WT&gt; key to switch between normal weighing and live weight mode. The display will briefly show <b>NORMAL</b> or <b>LIVE.WT</b>.</li></ul> |
|---|

During normal weighing, this key operates exactly like a manual <HOLD> key.

In Live-Weight mode the following sequence is followed:

- |  |
|--|
| <ul style="list-style-type: none"><li>• While the net weight is within the zero 'dead' band, the instrument shows the current weight.</li></ul>  |
| <ul style="list-style-type: none"><li>• Press the &lt;TARE&gt; or &lt;ZERO&gt; key to clear any residual weight and return the scale to the zero state.</li></ul>  |
| <ul style="list-style-type: none"><li>• Place the mass to be weighed on the scale.</li></ul>   |
| <ul style="list-style-type: none"><li>• Once the weight moves outside the zero 'dead' band the instrument begins to calculate a long term average that compensates for any movement in the mass. The instrument flashes the <b>Hold</b> annunciator and shows the current average value.</li></ul> |
| <ul style="list-style-type: none"><li>• The <b>Hold</b> annunciator is steady when the final sample weight is shown on the display.</li></ul>  |
| <ul style="list-style-type: none"><li>• Press the &lt;LIVE WT&gt; key to force the sample to be re-calculated.</li></ul>   |
| <ul style="list-style-type: none"><li>• Once the weight is returned to the zero 'dead' band, the cycle can be repeated.</li></ul>  |

### 11.2.7. SHOW.T

The **SHOW.T** item stands for **Show Total**. The function key will be labeled <TOTAL>.

The **PRINT** key is used not only to print the current weight but also to add that weight to the current total.

- |   |
|---|
| <ul style="list-style-type: none"><li>• When the &lt;TOTAL&gt; key is pressed the indicator displays <b>count</b> followed by the number of items in the total.</li></ul> |
| <ul style="list-style-type: none"><li>• After this, <b>TOTAL</b> is displayed followed by the current total weight.</li></ul>   |

If the total weight is too large to display in six digits, the weight is shown in two sections labeled with the upper six digits displayed before the lower six digits.

A long press of the <PRINT> key causes the total accumulated weight to be printed and then cleared. The SERIAL:TYPE option must be set to PRINT to activate this function.

# 12. Appendix

## 12.1. Dimensions

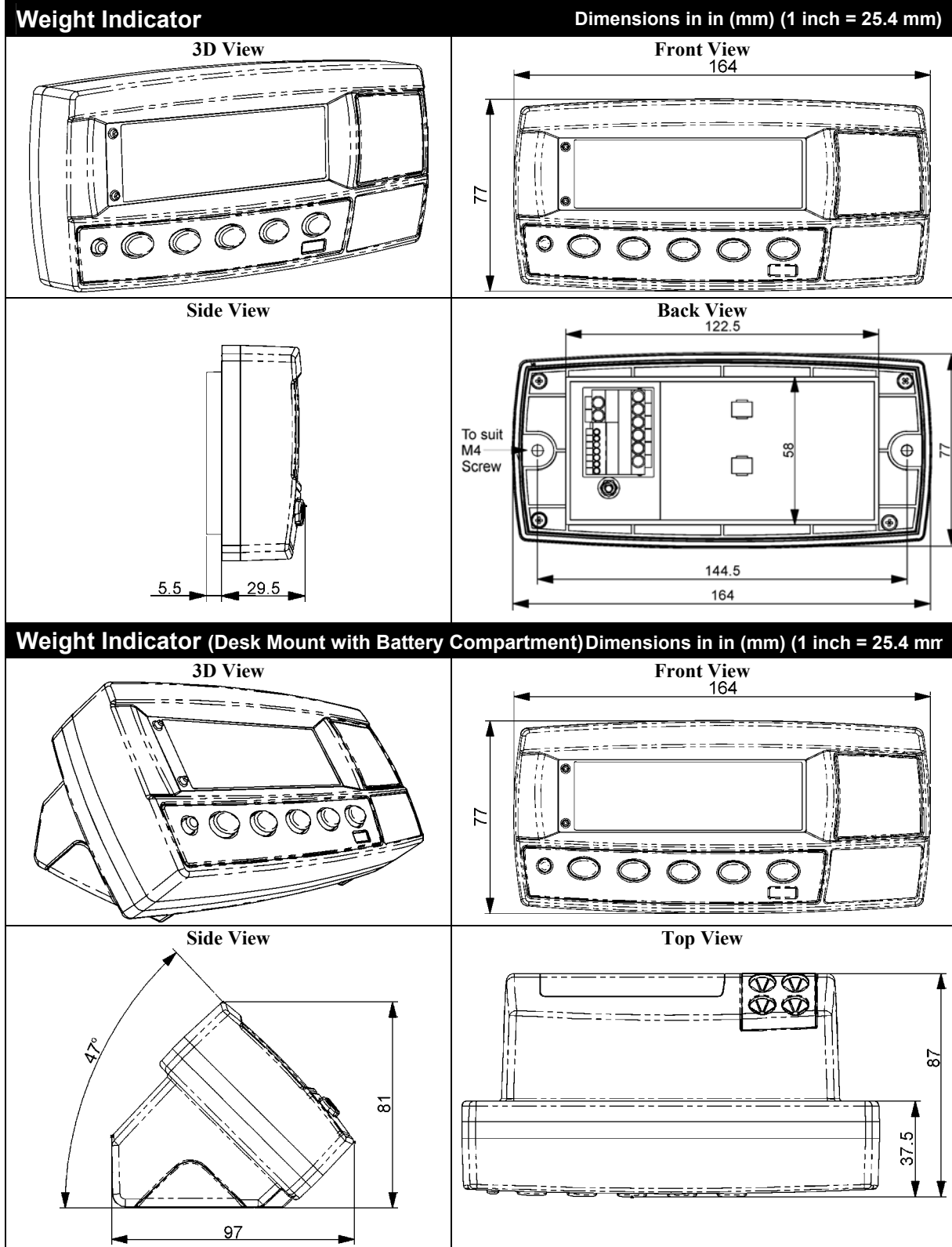



## 12.2. Sealing Details

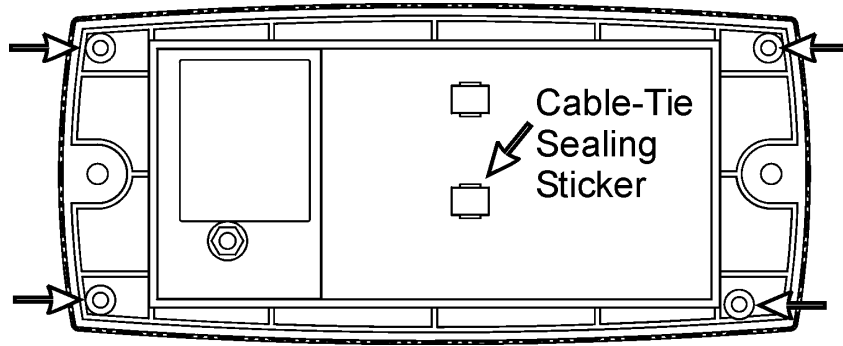

Affix sealing stickers to the rear of the instrument, over one or more screws in the locations indicated.

Also affix a sealing sticker over the load cell cable where the cable-tie strain relief is attached, as indicated.

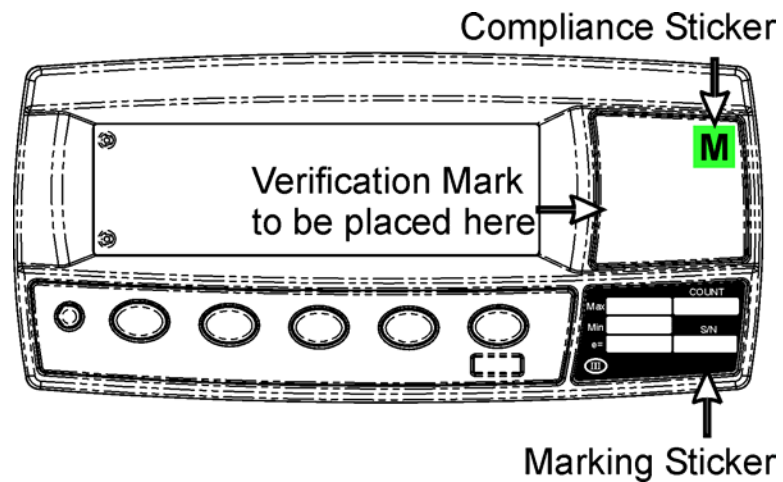

Affix stickers in the locations indicated.

### 12.3. Setup Menu Quick Reference

Note: ⊗ Available only in Full Setup. Changing this setting **will increment** the Calibration Counter.

1 Available only in Full Setup. Changing this setting **will not increment** the Calibration Counter.

Group (GRP)	Item (ITM)	Page	⊗
<b>BUILD</b>	DP (Decimal Point Position) ⊗	21	⊗
	CAP (Maximum Capacity) ⊗	21	⊗
	RES (Count-by Resolution) ⊗	21	⊗
	UNITS (Weighed Units) ⊗	21	⊗
	HI.RES (High Resolution x 10 mode) ⊗	21	⊗
	CABLE (4-Wire or 6-Wire) ⊗	22	⊗
<b>OPTION</b>	USE (Scale Use) ⊗	22	⊗
	FILTER (Reading Average)	22	
	MOTION (Motion Detection) ⊗	22	⊗
	INIT.Z (Initial-Zero on Startup)	22	
	Z.TRAC (Zero Tracking Sensitivity) ⊗	22	⊗
	Z.RANGE (Allowable Zero Operating Range) ⊗	22	⊗
	Z.BAND (Zero 'Dead' Band) ⊗	22	⊗
<b>CAL</b>	ZERO (Zero Calibration) ⊗	23	⊗
	SPAN (Span Calibration) ⊗	23	⊗
	ED.LIN (Edit Linearization Points) ⊗	23	⊗
	CLR.LIN (Clear Linearization Points) ⊗	23	⊗
	DIR.ZER (Direct Zero Calibration) ⊗	23	⊗
	DIR.SPN (Direct Span Calibration) ⊗	23	⊗
	FAC.CAL (Restore Default Factory Calibration) ⊗	23	⊗
<b>SPEC</b>	SAFE.PC (Safe Security Passcode for Digital Setup)	23	
	FULL.PC (Full Security Passcode for Digital Setup)	23	1
	KEY.LOC (Front Panel Key Locking)	24	
	KEY.FN (Key Functions)	24	
	AUT.OFF (Auto Power Off / Battery Operation)	24	
	B.LIGHT (Backlight Operation)	24	
	REM.FN (Remote Function)	24	
<b>SERIAL</b>	TYPE (Serial Output Type)	25	
	BAUD (Serial Baud Rate)	25	
	BITS (Serial Format Options)	25	
	ADDRES (Instrument Address)	25	
	RST.CON (Reset Printed Consecutive Number) ⊗	25	⊗
<b>SET.PTS</b>	SRC (Weight Source)	25	
	TARG.HI (Target for Overweight)	26	
	TARG.LO (Target for Underweight)	26	
<b>CLOCK</b>	FORMAT (Date Format)	26	
	YEAR (Set Year)	26	
	MONTH (Set Month)	26	
	DAY (Set Day)	26	
	HOUR (Set Hour)	26	
	MINUTE (Set Minute)	26	
<b>TEST</b>	SCALE (Scale Base Test Display)	26	
	FRC.OUT (Force Outputs)	26	
<b>FACTRY</b>	DEFLT (Restore Factory Settings Except for Calibration and Build)	27	1
<b>- END -</b>	Save settings and return to normal weighing mode. Refer to Exiting Full or Safe Setup	20	

## 12.4. Error Messages

A number of error messages may be displayed to warn of operation outside of the acceptable limits. These messages are described below. Short messages (XXXXX) will appear as a single message on the display. Longer messages (XXXXX) (YYYYY) will appear on the display in two parts, first the (XXXXX) part, then the (YYYYY) part.

### 12.4.1. Weighing Errors

These messages show status messages or errors that may occur during normal weighing operation.

Error	Description	Resolution
(U - - - -)	The weight is below the minimum allowable weight reading.	Increase the weight or decrease the minimum allowable weight reading.
(O - - - -)	The weight is above the maximum allowable weight reading. Warning - overloading may damage mechanical scale elements.	Check the condition of load cell connections. Check for damaged load cell.
(ZERO) (ERROR)	The weight reading is beyond the limit set for Zero operation. The operation of the <ZERO> key is limited in the setup during installation. The indicator cannot be Zeroed at this weight.	Increase the Zero Range (Z.RANGE) or use the <TARE> key instead.
(STABLE) (ERROR)	Scale motion has prevented a <ZERO> or <TARE> operation from occurring on command.	Try the operation again once the scale is stable.

### 12.4.2. Setup and Calibration Errors

These messages show status messages or errors that may occur during the instrument setup and calibration.

Error	Description	Resolution
(ENTRY) (DENIED)	The instrument may be in Safe Setup and an item that needs Full Setup has been selected for editing.	Access Full Setup to edit the item.
	When accessing setup, more than three attempts have been made with the incorrect passcode. Refer to Setup Lock-Out page 19 for more information.	Turn the instrument off. When the instrument is turned back on, enter the correct passcode to access setup.
(LIN.PT) (LO)	An attempt has been made to place a linearization point below zero.	Incorrect linearization point entered (must be between zero and full scale). Refer to Using Linearization page 29 for more information.
(PT.TOO) (CLOSE)	An attempt has been made to place a calibration point too close to an existing calibration point.	Re-enter the calibration point. Points must be spaced by at least 2% of full scale from each other. Refer to Using Linearization page 29 for more information.
(RES) (LO)	The scale build is configured for less than 100 graduations.	Check the resolution (count-by) and capacity settings.
(RES) (HIGH)	The scale build is configured for more than 30,000 graduations.	Check the resolution (count-by) and capacity settings.

Error	Description	Resolution
(SPAN) (LO)	The load cell signal range (span) is too small for these settings.	Incorrect span weight entered (must be between zero and full scale). Scale wiring incorrect. Wrong load cell capacity (too large). Wrong or no calibration weight added to scale.
(SPAN) (HI)	The load cell signal range (span) is too large for these settings.	Incorrect span weight entered (must be between zero and full scale). Scale wiring incorrect. Load cell capacity too small for application.
(ZERO) (LO)	An attempt has been made to calibrate zero below -2mV/V.	Scale wiring incorrect
(ZERO) (HI)	An attempt has been made to calibrate zero above +2mV/V.	Remove all weight from scale. Scale wiring incorrect.

## 12.5. Diagnostic Errors

The instrument continually monitors the condition of the internal circuits. Any faults or out-of-tolerance conditions are shown on the display as an **E** type error message.

In the table below the following terms are used:

- **Check:** This item can be checked on site by service personnel.
- **Return for Service:** The instrument must be returned to GSE Scale Systems for factory service.

Error	Description	Resolution
(E0001)	The power supply voltage is too low.	Check supply
(E0002)	The power supply voltage is too high.	Check scale / cables
(E0010)	The temperature is outside of allowable limits.	Check location
(E0020)	Scale build is incorrect. The number of graduations has been set too low or too high.	Fix up scale build
(E0100)	The digital setup information has been lost.	Re-enter setup
(E0200)	The calibration information has been lost.	Re-calibrate
(E0300)	All setup information has been lost	Enter setup and calibrate
(E0400)	The factory information has been lost.	Return for Service
(E0800)	The EEPROM memory storage chip has failed	Return for Service
(E2000)	ADC Out of Range Error. This may be caused from a broken load cell cable.	Check BUILD:CABLE setting. Check load cell cable, wiring, etc.
(E4000)	The battery backed RAM data has lost data.	Re-enter setup
(E8000)	The FLASH program memory is incorrect	Return for Service

The **E** type error messages are additive. For example if instrument is running off batteries and the temperature drops, the battery voltage may be too low. The resulting error messages will be **E 0011** (0001 + 0010). The numbers add in hexadecimal as follows:

**1 - 2 - 3 - 4 - 5 - 6 - 7 - 8 - 9 - A - B - C - D - E - F**  
(For example, 2 + 4 = 6, or 4 + 8 = C)

## 12.6. Glossary Terms

Term	Definition
Count-by	The smallest change in weight units that the display can show. See also Resolution.
Division	A single graduation.
EEPROM	Electrically Erasable Programmable Read-Only Memory
EMC	Electro-Magnetic Compatibility Regulation
FIR	Finite Impulse Response
Full Scale	The maximum gross weight allowed on the scale. This is used to detect

Term	Definition
	overload and underload conditions, etc.
Graduations	The maximum number of display steps between zero gross load and full capacity gross load. It is equal to the full scale divided by the resolution.
LED	Light Emitting Diode
NTEP	National Type Evaluation Program
OIML	International Organization of Legal Metrology
PLC	Programmable Logic Controller
Range	Total change in weight between zero gross load and full capacity gross load (i.e. the nominated total capacity of the scale). It is always given in displayed weight units.
Resolution	The smallest change in weight units that the display can show. See also Count-by.
RFI	Radio Frequency Interference
GSE-LINK Cable	Isolated infrared communications link cable
RS-232	Standard for communications hardware layers.
Step-Response	The step-response is the time between placing a weight on the scale and the correct weight reading being displayed.
Transients	A temporary voltage oscillation or spike caused by a sudden change of load (or other external influence).
Units	The actual units of measurement (kilograms, tons, pounds, etc.).

## 12.7. List of Figures

Figure 1: Weight Indicator .....	3
Figure 2: Cable Connections .....	7
Figure 3: 4-Wire Connections .....	8
Figure 4: 6-Wire Connections .....	8
Figure 5: RS-232 - Instrument to PC using COM Port (DB9).....	8
Figure 6: RS-232 – Instrument to PC using COM Port (DB25).....	9
Figure 7: RS-232 – Instrument to Printer (DB25).....	9
Figure 8: Remote Input .....	9
Figure 9: Instrument Outputs to Drive Relay.....	10
Figure 10: Instrument Outputs to Drive PLC.....	10
Figure 11: GSE-LINK Attachment.....	11
Figure 12: Cable Shield Connection .....	11
Figure 13: Editing Annunciators.....	12
Figure 14: Display and Controls Illustration .....	14
Figure 15: Chart - Zero and Span Points to Interpolate Weight from Load Cell.....	28
Figure 16: Chart - Non-Linear Characteristic for Load Cell Output .....	30

## 12.8. List of Tables

Table 1: Status Annunciators .....	14
Table 2: Industrial vs OIML and NTEP Modes.....	18

## 13. Index

- 4-Wire Connection, 7
- 6-Wire Connection, 8
- ADDRES, 26
- AUT.OFF, 25
- Automatic Weight Output, 32
- Auxiliary Connection, 8, 32, 34
- B.LIGHT, 25, 39
- Basic Operation, 15
- Basic Weighing Terminology, 18
- BAUD, 26, 39
- BITS, 26, 39
- BUILD, 22
- CABLE, 7, 8, 23, 39
- Cable Connections, 6
- CAL, 24
- Calibration, 29
- Calibration Counter, 19
- CAP, 22, 39
- Clear Linearisation, 31
- CLOCK, 27
- CLR.LIN, 24, 31, 39
- Communications Manual, 3
- Connecting Shields, 12
- COUNT, 35
- Data Entry, 13
  - Numeric Entry, 13
  - Selections and Options, 13
- DAY, 27
- DC Power Supply, 7
- DEFLT, 27
- Diagnostic Errors, 41
- Digital Calibration with Test Weights, 29
- DIR.SPN, 24, 39
- DIR.ZER, 24, 39
- Direct mV/V Calibration, 30
- Direct Span Calibration, 30
- Direct Zero Calibration, 30
- Document Conventions, 4
- DP, 22, 39
- Earthing, 12
- ED.LIN, 24, 31, 39
- Edit Linearisation Points, 31
- Editing Annunciators, 13, 16
- Electrical Safety, 6
- EMC Immunity, 6
- End – Leaving Setup, 28
- Error Messages, 40
- Exiting Digital Setup, 28, 39
- Exiting Full or Safe Setup, 31
- External Output Drivers - Connection, 34
- FAC.CAL, 24, 28, 39
- FACTRY, 27
- FILTER, 23
- FILTER (Reading Average), 39
- Filtering Techniques, 19
- FORMAT (Date), 27, 39
- FRC.OUT, 27, 39
- Front Panel, 15
  - Special Function Key, 35
- Full Digital Setup Passcode, 25
- Full Setup Passcode, 20
- FULL.PC, 24
- FUNCTION Key, 17, 35
- Function Keys, 16
  - Editing Function, 16
  - Primary Function, 16
- General Setup Information, 18
- Glossary of Terms, 41
- GROSS/NET Key, 17
  - opto-LINK Activation, 17
- Group and Items, 22
- Groups and Items, 22
- HI.RES, 22, 39
- HOLD, 35
- HOUR, 27
- Industrial vs OIML and NTEP Mode, 19
- INIT.Z, 23, 39
- Key Functions, 35
- KEY.FN, 25, 35, 39
- KEY.LOC, 25
- Keypad
  - Normal Operation, 13
- L.in P, 24, 31
- LIVE.WT, 36
- Load Cell Connection, 7
- Load Cell Signals, 7
- Master Serial Output, 33
- MINUTE, 27
- MONTH, 27
- MOTION, 16, 23, 39
- NONE, 35
- NVRAM, 3
- Operator Manual, 3
- OPTION, 23
- OPTION (Scale Options), 16
- opto-LINK, 10
- Outputs, 10
- Passcode, 18
- PEAK HOLD, 35
- POWER Key, 16
  - Automatic Operation, 16
- PRINT Key, 17
- Printing, 32
  - Counting Information, 32
  - Counting Sample, 32
  - Format, 32
  - Gross or Net, 32
- Quick Start Manual, 3
- Reference Manual, 3
- REM.FN, 25
- Remote Function, 9, 25, 26
- Remote Input, 9
- RES, 22, 23, 39
- Restore Factory Settings, 27
- RFI, 42
- RS-232 Serial, 8
- RST.CON, 26
- S.in P, 24, 30
- Safe Setup Passcode, 20
- SAFE.PC, 24
- SCALE, 7, 39
- SCALE (Scale Base Test Display), 27
- Scale Build, 7, 24
- Sealing Details, 38
- Sealing Requirements, 12
- SERIAL, 26, 32
- Serial Communications, 32
- Serial Output, 32
- Serial PC Link, 8
- Serial Printer Connections, 9
- Serial Remote Display, 9
- SET.PTS, 26
- Setpoint Operation, 34
- Setpoints, 34

Setup Display Prompts, 21  
Setup Errors, 40  
Setup Menu Quick Reference, 39  
SHOW.T, 36  
Sigma-Delta A/D converter, 3  
SPAN, 24, 39  
Span Calibration Routine, 30  
SPEC, 24  
Special Functions, 35  
Specifications, 4, 5  
SRC, 26  
Stability Considerations, 16  
TARE Key, 17  
TARG.HI, 26, 34  
TARG.LO, 27, 34  
TEST, 35

TEST (Special Test Functions), 27  
TYPE (Serial Output), 26  
UNITS, 22, 35, 39  
Units Display, 15  
USE, 19, 23, 39  
Using Linearisation, 30, 40  
Weighing Errors, 40  
Weight Display, 15  
YEAR, 27  
Z.BAND, 23, 39  
Z.in P, 24, 30  
Z.RANGE, 17, 23, 39  
Z.TRAC, 23, 39  
ZERO, 24, 39  
Zero Calibration Routine, 30  
ZERO Key, 16

**Notes:**





**Model 250 Technical Reference Manual**

Part Number: 39-10-42438